



# RD-E Series Modified Sine Wave Inverters/Chargers



Owner's Manual

## Disclaimer of Liability

The use of this manual and the conditions or methods of installation, operation, use, and maintenance of the RD-E Series Inverter/Charger is beyond the control of Magnum Energy Inc. Therefore, this company assumes no responsibility and expressly disclaims any liability for loss, damage, or expense whether direct, indirect, consequential, or incidental that may arise out of or be in anyway connected with such installation, operation, use, or maintenance.

Due to continuous improvements and product updates, the images shown in this manual may not exactly match the unit purchased.

## Restrictions on Use

The RD-E Series Inverter/Charger may only be used in life-support devices or systems with the express written approval of Magnum Energy. Failure of the RD-E Series Inverter/Charger can reasonably be expected to cause the failure of that life-support device or system, or to affect the safety or effectiveness of that device or system. If the RD-E Series Inverter/Charger fails, it is reasonable to assume that the health of the user or other persons may be endangered.

## Copyright Notice

Copyright © 2004, 2010 by Magnum Energy, Inc. All rights reserved. Permission to copy, distribute, and/or modify this document is prohibited without express written permission by Magnum Energy, Inc.

## Contact Information

Magnum Energy, Inc.  
2211 West Casino Rd.  
Everett, WA 98204  
Phone: 425-353-8833  
Fax: 425-353-8390  
Web: [www.magnumenergy.com](http://www.magnumenergy.com)

Record the unit's model and serial number in case you need to provide this information in the future. It is much easier to record this information now, instead of trying to gather it after the unit has been installed.	
Model:	Serial Number:
<input type="checkbox"/> RD2624E	Z1
<input type="checkbox"/> RD4024E	W1

Magnum Energy® is a registered trademark of Magnum Energy, Inc.

# IMPORTANT SAFETY INSTRUCTIONS

- This manual contains important safety instructions that must be followed during the installation and operation of this product.
- All electrical work must be performed in accordance with local, state and federal electrical codes.
- Read all instructions and safety information contained in this manual before installing or using this product.
- This product is designed for indoor/compartment installation. It must not be exposed to rain, snow, moisture, or liquids of any type.
- Use insulated tools to reduce the chance of electrical shock or accidental short circuits.
- Remove all jewelry such as rings, watches, bracelets, etc., when installing or performing maintenance on the inverter.
- Always disconnect the batteries or energy source prior to installing or performing maintenance on the inverter.
- Live power may be present at more than one point since an inverter utilizes both batteries and AC.
- Always verify proper wiring prior to starting the inverter.
- There are no user-serviceable parts contained in this product.
- This unit is provided with integral protection against overloads.
- The input and output AC and DC circuits are isolated from the inverter chassis. The inverter system grounding is the responsibility of the installer in accordance with the NEC/CEC and local codes.
- Both AC and DC overcurrent protection must be provided as part of the installation.
- Use Class 1 wiring methods for field-wiring connections to terminals of a Class 2 circuit.
- Use only copper wires with a minimum temperature rating of 90°C.
- Listed or labeled equipment shall be installed and used in accordance with any instructions included in the listing or labeling.

## Safety Symbols

To reduce the risk of electrical shock, fire, or other safety hazard, the following safety symbols have been placed throughout this manual to indicate dangerous and important safety instructions.



**WARNING:** This symbol indicates that failure to take a specified action could result in physical harm to the user.



**CAUTION:** This symbol indicates that failure to take a specified action could result in damage to the equipment.



**Info:** This symbol indicates information that emphasizes or supplements important points of the main text.



**Remedy:** This symbol provides possible solutions for related issues.

## SAVE THESE INSTRUCTIONS

## **IMPORTANT BATTERY SAFETY INSTRUCTIONS**

- Be very careful when working around batteries, they can produce extremely high currents if short-circuited. Read the battery supplier's precautions before installing the inverter and batteries.
- Wear eye protection such as safety glasses when working with batteries.
- Remove all jewelry such as rings, watches, bracelets, etc., when installing or performing maintenance on the inverter.
- Never work alone. Always have someone near you when working around batteries.
- Use proper lifting techniques when working with batteries.
- Never use old or untested batteries. Check each battery's label for age, type, and date code to ensure all batteries are identical.
- Batteries are sensitive to changes in temperature. Always install batteries in a stable environment.
- Install batteries in a well ventilated area. Batteries can produce explosive gases. For compartment or enclosure installations, always vent batteries to the outside.
- Provide at least one inch (2.5 cm) of air space between batteries to provide optimum cooling.
- Never smoke in the vicinity of batteries.
- To prevent a spark at the battery and reduce the chance of explosion, always connect the cables to the batteries first. Then connect the cables to the inverter.
- Use insulated tools at all times.
- Always verify proper polarity and voltage before connecting the batteries to the inverter.
- To reduce the chance of fire or explosion, do not short-circuit the batteries.
- In the event of accidental exposure to battery acid, wash thoroughly with soap and water. In the event of exposure to the eyes, flood them for at least 15 minutes with running water and seek immediate medical attention.
- Recycle old batteries.

## **SAVE THESE INSTRUCTIONS**

# Table of Contents

<b>1.0</b>	<b>Introduction</b>	<b>1</b>
1.1	Features and Benefits	2
1.2	How an Inverter/Charger Works	5
1.3	What Appliances will run from a Modified Sine Wave Inverter	5
1.4	Appliances and Run Time	5
<b>2.0</b>	<b>Installation</b>	<b>7</b>
2.1	Pre-Installation	7
2.2	Mounting the Inverter	10
2.3	Wiring the Inverter - General Requirements	12
2.4	DC Wiring	13
2.5	AC Wiring	19
2.6	Grounding Inverters	24
2.7	Inverter Notification Requirements	28
2.8	Final Inspection	28
2.9	Functional Test	29
<b>3.0</b>	<b>Operation</b>	<b>30</b>
3.1	Inverter Mode	30
3.2	Standby Mode	31
3.3	Battery Charging	31
3.4	Transfer Time	33
3.5	Battery Temperature Sensor Operation	33
3.6	Protection Circuitry Operation	34
3.7	Inverter Startup	35
3.8	Factory Default Values	36
<b>4.0</b>	<b>Maintenance and Troubleshooting</b>	<b>37</b>
4.1	Recommended Inverter and Battery Care	37
4.2	Troubleshooting	38
4.3	Resetting the Inverter	39
<b>Appendix A</b>	<b>- Specifications and Optional Equipment</b>	<b>40</b>
A-1	Inverter/Charger Specifications	40
A-2	Optional Equipment and Accessories	41
A-3	Wiring Color Codes for Europe and the U.S./Canada	42
<b>Appendix B</b>	<b>- Battery Information</b>	<b>43</b>
B-1	Battery Location	43
B-2	Battery Types	43
B-3	Battery Temperature	43
B-4	Battery Bank Sizing	43
B-5	Battery Bank Sizing Worksheet	44
B-6	Battery Wiring Configurations	45
	<b>Limited Warranty</b>	<b>47</b>
	<b>How to Receive Repair Service</b>	<b>47</b>

# List of Figures

Figure 1-1, Power Switch, Status LED, and Accessory Connection Ports.....	3
Figure 1-2, Electrical Connection Points .....	3
Figure 1-3, Left Side Features .....	4
Figure 2-1, Simplified Installation Diagram for Permanent Installations .....	8
Figure 2-2, Approved Mounting Positions .....	10
Figure 2-3, RD-E Series Dimensions and Side Reference .....	11
Figure 2-4, DC and Battery Temperature Sensor Wiring .....	14
Figure 2-5, Battery Hardware Installation .....	16
Figure 2-6, Inverter DC Hardware Installation .....	16
Figure 2-7, Battery Temperature Sensor .....	17
Figure 2-8, RD-E Series Inverter/Charger - AC Wiring .....	20
Figure 2-9, RD-E Series Inverter/Charger - AC Wiring (Access Cover) .....	20
Figure 2-10, AC Terminal Block.....	21
Figure 2-11, AC Wiring Input/Output.....	23
Figure 2-12, Grounding System for RD-E Series.....	24
Figure 2-13, Multiple Connections to DC Ground Rod (Method 1).....	25
Figure 2-14, Multiple Connections to DC Ground Rod (Method 2).....	26
Figure 2-15, Single Connection to DC Ground Rod (Method 3) .....	26
Figure 2-16, Warning Label .....	28
Figure 2-17, AC Voltage Checks.....	29
Figure 3-1, Power Flow - Inverter Mode .....	30
Figure 3-2, Power Flow - Standby Mode .....	31
Figure 3-3, Automatic 4-Stage Charging Graph.....	32
Figure 3-4, BTS Temperature to Charge Voltage Change .....	33
Figure 3-5, Power Switch and Status Indicator.....	35
Figure 4-1, Performing an Inverter Reset .....	39
Figure B-1, Series Battery Wiring.....	45
Figure B-2, Parallel Battery Wiring .....	45
Figure B-3, Series-Parallel Battery Wiring.....	45
Figure B-4, Battery Bank Wiring Examples (24-volt).....	46

# List of Tables

Table 1-1, Typical Appliance Power Consumption.....	6
Table 2-1, Recommended DC Wire/Overcurrent Device for Rated Use .....	15
Table 2-2, DC Wire Size For Increased Distance .....	16
Table 2-3, AC Grounding Electrode Conductor Sizing .....	25
Table 2-4, Equipment Grounding Conductor Sizing .....	27
Table 3-1, Inverter Battery Turn On/Off Levels.....	34
Table 3-2, Inverter/Charger Default Values .....	36
Table 4-1, Basic Troubleshooting.....	38
Table A-1, AC Wiring Color Codes.....	42
Table A-2, DC Wiring Color Codes .....	42

### 1.0 Introduction

Congratulations on your purchase of the RD-E Series inverter/charger from Magnum Energy. The RD-E Series is a modified sine wave inverter designed especially for renewable energy systems. Powerful, yet simple to operate, this inverter/charger will provide you with the years of trouble-free performance you have come to expect from Magnum Energy, all backed by our limited 2 year warranty.

Installation is easy. Simply connect the inverter's output to your distribution circuits or electrical panel, connect your utility or AC generator power to the inverter's easy-to-reach terminal block, connect the batteries, and then switch it on for power.

Use the optional accessories listed below to control and monitor many other Magnum devices.

The RD-E Series inverter/charger includes:

- 2600 or 4000 watt models in a small footprint – less weight and area needed for installation (shelf, bulkhead, or upside-down mounting)
- Modified Sine Wave output
- Automatic Power Factor Corrected (PFC) multi-stage battery charging
- RS485 standard communication protocol
- Remote and Network ports (easy connection for optional accessories)
- ON/OFF inverter-mounted switch with LED indicator
- 30 Amp per leg/input
- Large AC access and terminal block [wire size: 10 to 6 AWG (5.3 to 13.3 mm<sup>2</sup>) CU]
- DC terminal covers with 360 degree connection
- Field-serviceable for qualified personnel – tested repair kits available
- Automatic battery temperature compensation (using battery temperature sensor) – for optimum charging even during extreme temperature changes
- Overcurrent, over-temperature, and high/low battery voltage protection

The following accessories are also available for use with the RD-E Series inverter/charger:

- **ME-RC50** (Basic Remote Control) - easy to read LCD display panel that enables standard inverter and accessories set up, control, and troubleshooting.
- **ME-ARC50** (Advanced Remote Control) - easy to read LCD display panel that enables advance inverter and accessories set up, control, and troubleshooting.
- **ME-AGS-N** (Automatic Generator Start Module - Network version) - automatically starts/stops your generator.
- **ME-BMK** (Battery Monitor Kit - with Shunt) - provides precise DC voltage/current measurements and provides information on your battery's State of Charge (SOC) condition.
- **MPX-CB** (Conduit Box) - provides several knockouts for connecting AC and DC conduit runs to the inverter.
- **ME-SBC** (Smart Battery Combiner) - monitors and keeps a second battery charged using a portion of the current that is charging a main battery.
- **MMP** (Mini Magnum Panel) - combines all of the major components required for a renewable energy system into a single, easy to install pre-wired enclosure.

## 1.1 Features and Benefits

The RD-E Series inverter/charger is designed to allow easy access to wiring, circuit breakers, and controls. Its die cast baseplate with one-piece aluminum cover ensures maximum durability with minimum weight, as well as cooler more efficient operation.

The front of the RD-E Series is equipped with the following features (see Figures 1-1 and 1-2):

- 1 **Power ON/OFF Switch** - a momentary pushbutton switch that alternately turns the inverter On or Off.
- 2 **Status LED Indicator** - this green LED illuminates to provide information on the inverter or charger operation.
- 3 **Stack/Accessories Connection Port (red label)** - a RJ11 port that accepts the optional Remote Switch Adapters (RSAs) which enable remote on/off switch operation.



**Info:** The stacking feature is NOT available with the RD-E Series.

- 4 **Network Connection Port (green label)** - a RJ11 port that accepts optional network capable accessories (e.g., Auto Gen Start or Battery Monitor).
- 5 **Remote Connection Port (blue label)** - a RJ11 port that allows the optional remote controls (ME-RC50 or ME-ARC50) to be connected.
- 6 **BTS Connection Port (yellow label)** - RJ11 port that accepts the remote Battery Temperature Sensor (BTS) accessory.
- 7 **DC Equipment Ground Terminal** - this connection is used to tie the exposed chassis of the inverter to the DC grounding system. This terminal accepts CU/AL conductors from #14 to #2 AWG (2.1 to 33.6 mm<sup>2</sup>).
- 8 **AC Input/Output Connections** - two 3/4" knockouts provided with cable-clamp strain reliefs to allow and hold the AC input and output field wiring.
- 9 **Intake Air Vents** - ventilation openings to pull in air to help keep the inverter cool for peak performance.
- 10 **Positive DC Terminal** - provides 360 degree connection point for the positive (+) cable from the battery bank; provided with a Kep or Flange nut on a 5/16-18 bolt (5/8" usable length) to hold the battery cable to the DC terminal.
- 11 **Negative DC Terminal** - provides 360 degree connection point for the negative (-) cable from the battery bank; provided with a Kep or Flange nut on a 5/16-18 bolt (5/8" usable length) to hold the battery cable to the DC terminal.
- 12 **Mounting Flange** - used to secure the inverter to a shelf or wall.



## Introduction

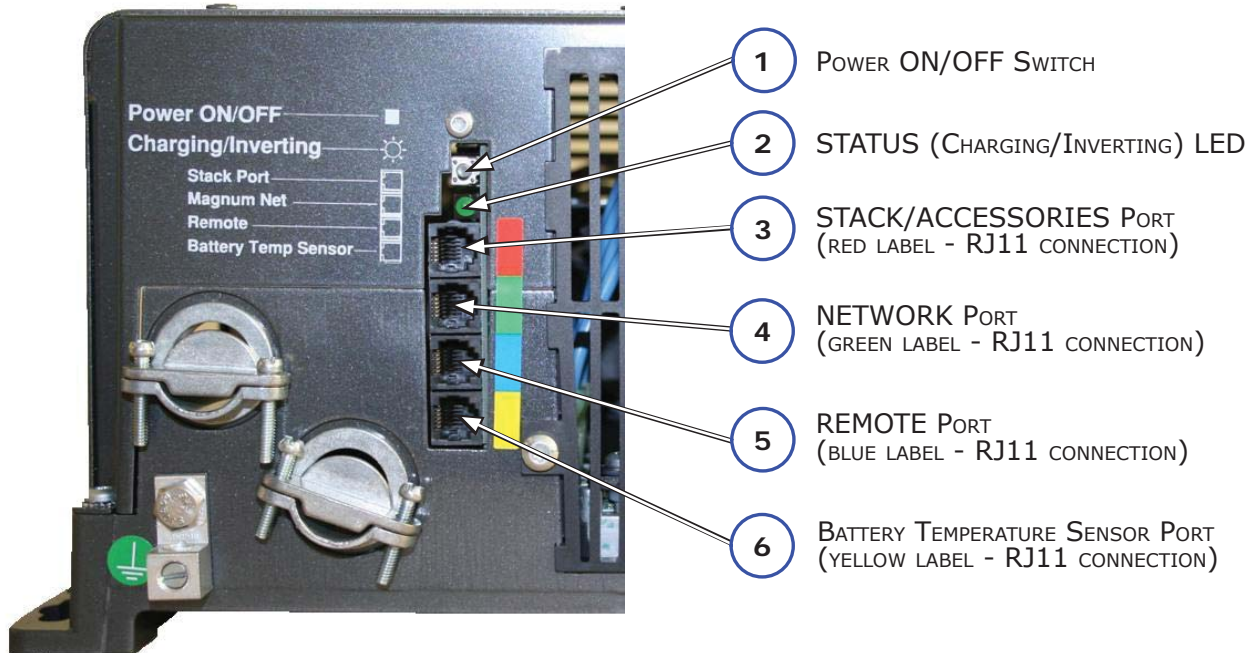

*Figure 1-1, Power Switch, Status LED, and Accessory Connection Ports*

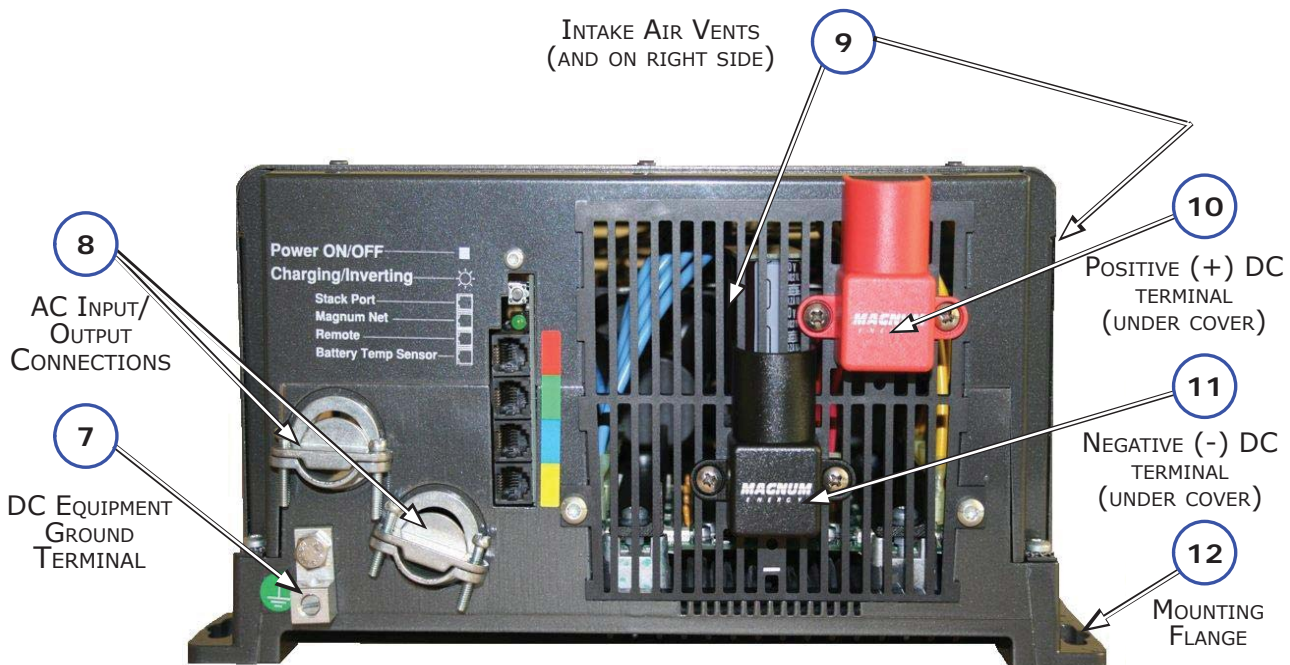

*Figure 1-2, Electrical Connection Points*

The left side of the RD-E Series is equipped with the following features (see Figure 1-3):

- 13 **Exhaust Air Vent** - ventilation openings that allow heated air to be removed by the internal cooling fan.
- 14 **Model/Serial Number Label** - includes model/serial number information, date of manufacture, and inverter and charger specifications. See the **RD-E Specifications** in Appendix A for more information and the different models that are available.
- 15 **AC Access Cover** - provides access to the internal AC wiring terminal block. This terminal block is used to hardwire all inverter AC input and output wiring connections. Remove the two screws to access the AC wiring terminal block.
- 16 **Input Circuit Breaker** - this circuit breaker protects the unit's internal charger wiring and pass-thru relay while in Standby mode. This circuit breaker will pop out when it opens. Press in to reset. This input circuit breaker is not branch-circuit rated, therefore, branch-circuit rated breakers must be installed in the inverter's input wiring.



**CAUTION:** The inverter's internal AC transfer relay is rated for 30 amps per leg. The pass-thru current must be no greater than 30 amps per leg or damage to the relays may occur.

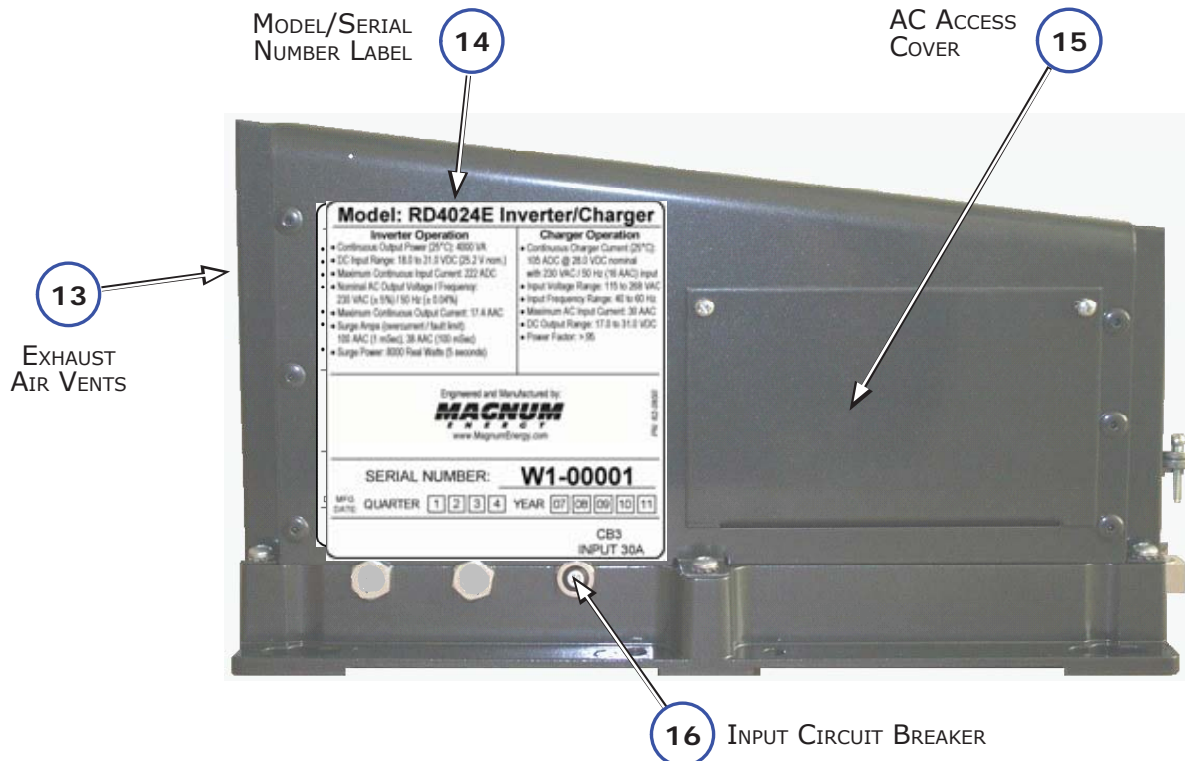

**Figure 1-3, Left Side Features**

## Introduction

### 1.2 How an Inverter/Charger Works

An inverter takes direct current (DC) from your batteries and turns it into alternating current (AC). It also takes alternating current (when connected to a generator or to utility power) and transforms it into direct current to charge your batteries. These two modes of operation associated with this inverter/charger are referred to in this document as:

- **Inverter Mode:**

When the inverter is properly connected to batteries and turned on, the direct current (DC) from the batteries is transformed into a modified sine wave alternating current (AC). This AC is similar to the voltage provided by a utility for your home, and is used to power the AC electrical appliances (i.e., AC loads) connected to the inverter's output.

- **Standby Mode:**

When an external source of AC power (e.g., utility power or generator) is connected and qualified on the inverter's AC input, it operates in the Standby mode. In the Standby mode, the unit operates as a battery charger to convert the incoming AC power into DC power to recharge the batteries; and at the same time, automatically closes an internal AC transfer relay to pass the incoming AC power directly to the inverter's output to continue powering the connected electrical appliances.

#### 1.2.1 Inverter Applications for Permanent Installations

An inverter can be used for backup power in a permanent location that normally uses utility power, such as a home or office. When the utility power is available, the inverter keeps the batteries charged. When the utility power fails, the inverter comes on automatically to supply AC power to your home or office during the power failure. For a home or business, reliable backup power is needed to prevent lost computer data, or to maintain lights and keep food fresh in the refrigerator/freezer.

In some areas where utility power is not available, the inverter can be used in a standalone renewable power system. The inverter enables AC electrical appliances to be run from the storage battery bank. When the battery bank becomes discharged, either renewable DC sources (solar, wind, or hydropower) can be used to recharge the batteries, or a generator can be connected to the inverter to power the system while the batteries recharge.

### 1.3 What Appliances will run from a Modified Sine Wave Inverter

Today's inverters come in two basic output waveforms: modified sine wave (which is actually a modified square wave) and pure sine wave. Modified sine wave inverters approximate a pure sine waveform and will run most appliances and electronics without any problems. These inverters are less expensive, and therefore, offer a viable alternative to more expensive pure sine inverters.

The output of a modified sine wave inverter will run most electronic and household items, including but not limited to: TV, VCR, satellite dish receiver, computers, and printers. Some devices such as rechargeable power supplies for phones, drills, and other like items may not run, and could even be at risk for damage from modified sine wave inverters.

### 1.4 Appliances and Run Time

The RD-E Series inverter/charger can power a wide range of household appliances including small motors, hair dryers, clocks, and other electrical devices. As with any appliance using batteries for power, there is a certain length of time that it can run – this is called "run time." Actual run time depends on several variables, including: the size and type of appliance, the type of batteries installed in your application, as well as the battery's capacity and age. Other factors such as the battery's state of charge (SOC) and temperature can also affect the length of time your appliances can run.

Depending on your inverter capacity, electrical appliances that use larger loads such as coffee pots and hair dryers can be used for short durations. However, loads that are used for longer periods (stoves, water heaters, etc.) can quickly drain your batteries and are not recommended for inverter applications.

All electrical appliances are rated by the amount of power they consume (see Table 1-1). The rating is printed on the product's nameplate label, usually located on its chassis near the AC power cord. Even though it is difficult to calculate exactly how long an inverter will run a particular appliance, the best advice is trial and error. Your RD-E Series inverter has a built-in safeguard that automatically protects your batteries from over-discharge.



**Info:** For optimum performance, a minimum battery bank of 200 AH is recommended for moderate loads (<1000W) and greater than 400 AH for heavy loads ( $\geq$ 1000W).

***Table 1-1, Typical Appliance Power Consumption***

<b>Device</b>	<b>Load</b>	<b>Device</b>	<b>Load</b>
Blender	400W	Coffee Maker	1200W
Computer	300W	Color TV	150W
VCR	40W	Hair Dryer	1000W
Hot Plate	1800W	Iron	1000W
Light (Flo)	10W	Light (Inc)	100W
Microwave	1000W	Refrigerator	500W

### 2.0 Installation



**WARNING:** Installations should be performed by qualified personnel, such as a licensed or certified electrician. It is the installer's responsibility to determine which safety codes apply and to ensure that all applicable installation requirements are followed. Applicable installation codes vary depending on the specific location and application of the installation.



**CAUTION:** Review the "Important Product Safety Information" on page ii, and the "Important Battery Safety Instructions" on page iii before any installation.



**CAUTION:** The inverter is heavy. Use proper lifting techniques during installation to prevent personal injury.

The simplified system diagram shown in Figure 2-1 should be reviewed to assist you in planning and designing your installation. This drawing is not intended to override or restrict any national or local electrical codes. This drawing should not be the determining factor as to whether the installation is compliant, that is the responsibility of the electrician and the onsite inspector.

#### 2.1 Pre-Installation

Before installing the inverter, read the entire installation section to determine how you are going to install your RD-E inverter/charger. The more thorough you plan in the beginning, the better your inverter needs will be met.

##### 2.1.1 Unpacking and Inspection

Carefully remove the RD-E Series inverter/charger from its shipping container and inspect all contents. Verify the following items are included:

- The RD-E inverter/charger
- Red and black DC terminal covers with Phillips screws
- AC access cover with two Phillips screws
- Two 5/16" Kep or Flange nuts (installed on the DC terminals)
- Battery Temperature Sensor
- Warning label
- RD-E Series Owner's Manual

If items appear to be missing or damaged, contact your authorized Magnum Energy dealer or Magnum Energy. If at all possible, keep your shipping box. It will help protect your inverter from damage if it ever needs to be returned for service. Save your proof-of-purchase as a record of your ownership; it will also be needed if the unit should require in-warranty service.

Record the unit's model and serial number in the front of this manual in case you need to provide this information in the future. It is much easier to record this information now, instead of trying to gather it after the unit has been installed.

##### 2.1.2 Required Tools and Materials

###### Hardware/Materials

- Conduit, strain-reliefs, and appropriate fittings
- Mounting bolts and lock washers
- Electrical tape
- Wire ties

###### Tools

- Miscellaneous screwdrivers
- Pliers
- Wire strippers
- Drill and drill bits
- Pencil or marker
- Multimeter
- Level
- 1/2" wrench

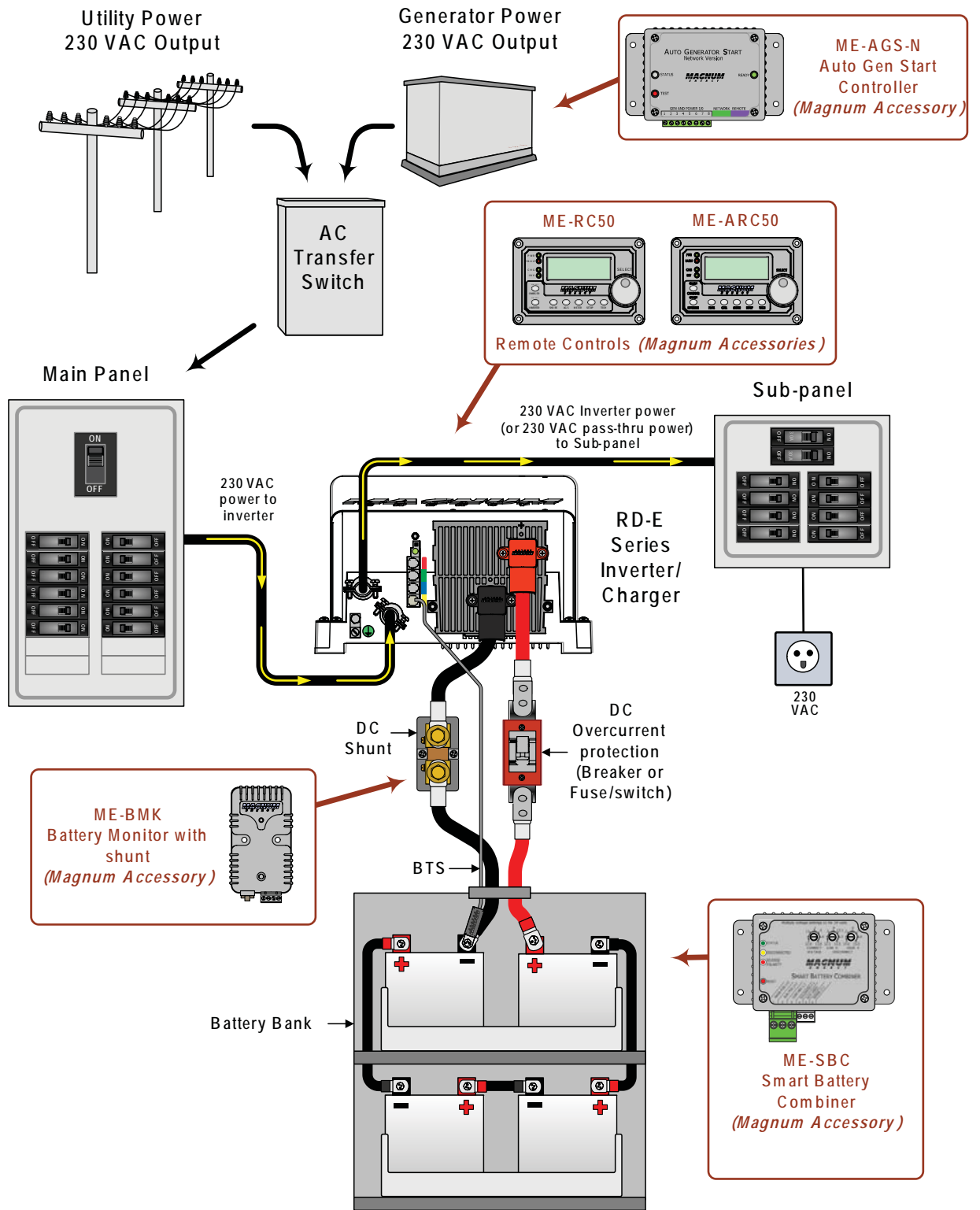

Figure 2-1, Simplified Installation Diagram for Permanent Installations

## Installation

### 2.1.3 Locating the Inverter

Only install the inverter in a location that meets the following requirements:

**Clean and Dry** - The inverter should not be installed in an area that allows dust, fumes, insects, or rodents to enter or block the inverter's ventilation openings. This area also must be free from any risk of condensation, water, or any other liquid that can enter or fall on the inverter. The inverter uses stainless steel fasteners, plated copper busbars, and a power-coated aluminum base. The internal circuit boards are conformal coated. All of this is done to help fight the harmful effects of corrosive environments. However, the inverter's life is uncertain if used in the above types of environments, and inverter failure under these conditions is not covered under warranty.



**Info:** If the inverter is installed in an area where moisture may occur, we recommend putting silicone dielectric grease compound into the electrical ports (see Figure 1-1, Items 3-6). Before installing the cables, or if leaving any ports open, squirt a liberal amount into each port. Silicone dielectric makes an effective moisture and corrosive barrier to help protect and prevent corrosion to the RJ11 connections.

**Cool** - The inverter should be protected from direct sun exposure or equipment that produces extreme heat. The ambient temperature around the inverter must not exceed 77°F (25°C) to meet power specifications.

**Ventilation** - In order for the inverter to provide full output power and avoid over-temperature fault conditions; do not cover or block the inverter's ventilation openings, or install this inverter in an area with limited airflow. The inverter uses two fans to provide forced-air cooling. These fans pull in air through the intake vents (see Figure 1-2, Item 9) and blow out air through the exhaust vents (see Figure 1-3, Item 13). Allow at the minimum an airspace clearance of 6" (15.2 cm) at the intake and exhaust vents, and 3" (7.6 cm) everywhere else to provide adequate ventilation.

If installed in an enclosure, a fresh-air intake opening must be provided directly to the front side (intake vents) of the inverter, and an exhaust opening on the back side (exhaust vents) of the inverter. This allows cool air from the outside to flow into the inverter, and heated air to exit the inverter and the enclosure. When mounted in an enclosed compartment, airflow must be ≥ 100 cfm in order to maintain no more than a 68°F (20°C) rise in compartment temperature.



**CAUTION:** Do not mount this inverter in a zero clearance compartment, nor cover or obstruct the ventilation openings – overheating may result.

**Safe** - Keep any flammable/combustible material (e.g., paper, cloth, plastic, etc.) that may be ignited by heat, sparks, or flames at a minimum distance of 2 feet (61 cm) away from the inverter. Do not install this inverter in any area that contains extremely flammable liquids like gasoline or propane, or in locations that require ignition-protected devices.

**Close to the battery bank** - As with any inverter, it should be located as close to the batteries as possible. Long DC wires tend to loose efficiency and reduce the overall performance of an inverter. However, the unit should NOT be installed in the same compartment as the batteries, or mounted where it will be exposed to gases produced by the batteries. These gases are corrosive and will damage the inverter; also, if these gases are not ventilated and allowed to collect, they could ignite and cause an explosion.



**Info:** The battery bank should be installed in a clean, dry, ventilated environment where they are protected from high and low temperatures. The batteries must be mounted upright (if using liquid batteries) and securely fastened. The location must be fully accessible and protected from exposure to heat producing devices, and away from any fuel tanks.

**Accessible** - Do not block access to the inverter's remote control and accessory ports, as well as the inverter's controls and status indicator. Also allow enough room to access the AC and DC wiring terminals and connections, as they will need to be checked and tightened periodically. See Figure 2-3 for the RD-E Series' inverter/charger dimensions.

**Away from sensitive electronic equipment** - High-powered inverters can generate levels of RFI (Radio Frequency Interference). Locate any electronic equipment susceptible to radio frequency and electromagnetic interference as far away from the inverter as possible.

## 2.2 Mounting the Inverter

The inverter base can reach a temperature up to 90°C (194°F) and it is recommended that it should be mounted on a non-combustible surface\*. This surface and the mounting hardware must also be capable of supporting at least twice the weight of the inverter. To meet regulatory requirements, the RD-E Series must be mounted in one of the following positions, as shown in Figure 2-2:

- above or under a horizontal surface (shelf or table)
- or, on a vertical surface (wall) with the DC terminals to the right
- or, on a vertical surface (wall) with DC terminals toward the bottom, MP-HOOD (inverter hood) installed on the top, and either the ME-CB (Conduit Box), MPX-CB (Conduit Box), or the MMP Series (single inverter) enclosure installed on the inverter's bottom.



**Info:** The ME-CB and MPX-CB conduit boxes prevent material from falling out the bottom in the event of an internal fire. The MP-HOOD inverter hood helps prevent items from falling inside, causing damage to the inverter.

After determining the mounting position, refer to the physical dimensions as shown in Figure 2-3, or use the base of the inverter as a template to mark your mounting screw locations.

\* *Non-combustible surface* - A surface made of material that will not ignite, burn, support combustion, or release flammable vapors when subjected to fire or heat as per the ASTM E136 standard. For the most part, these are materials that are largely comprised of inorganic matter such as stone, steel, iron, brick, tile, concrete, slate, and glass. Avoid common building materials such as gypsum board, painted surfaces, wall coverings, and any type of wood.

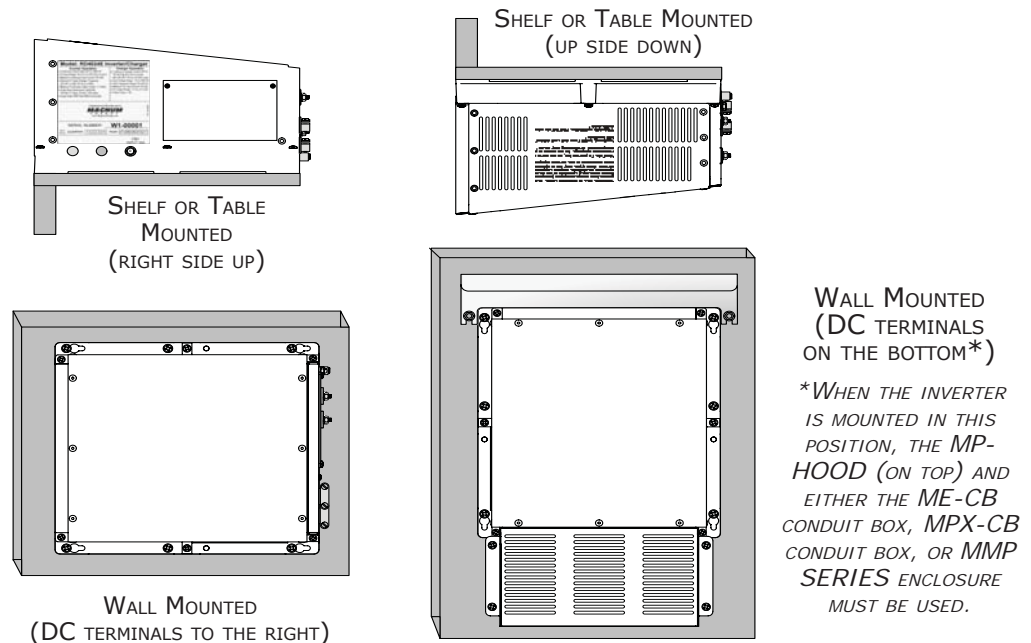

**Figure 2-2, Approved Mounting Positions**



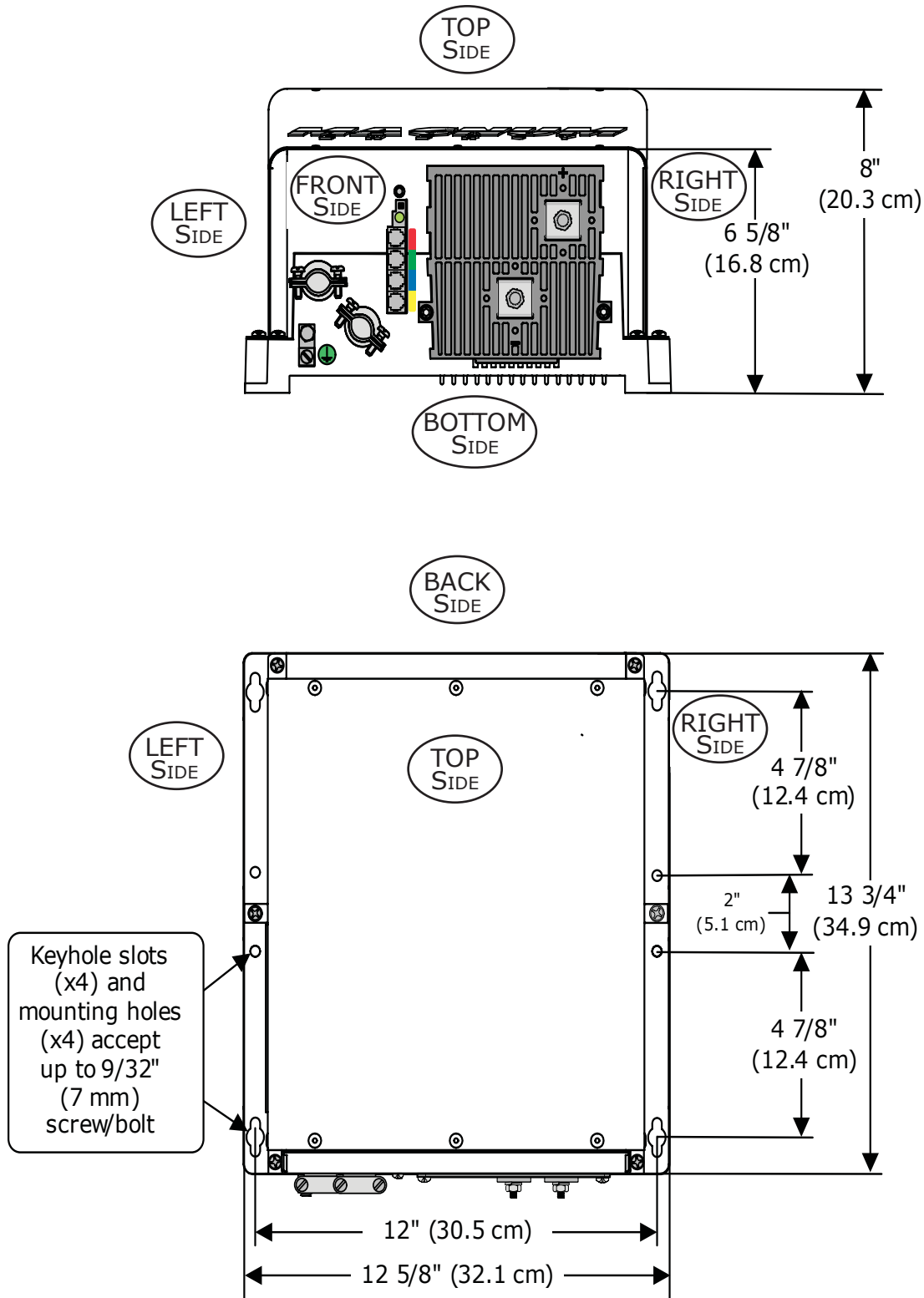

Figure 2-3, RD-E Series Dimensions and Side Reference

## 2.3 Wiring the Inverter - General Requirements

This section describes the requirements and recommendations for wiring the RD-E Series inverter/charger. Before wiring the inverter/charger, read all instructions.

**All wiring should meet all local codes and industry standards, and be performed by qualified personnel such as a licensed electrician.**



**Info:** This document uses the term “ground”, or “grounding”; the European equivalent is “earth”, or “earthing”. Refer to Appendix A-3 for equivalent AC/DC wiring terminology.

Inverter/charger systems involve power from multiple sources (e.g., inverter, generator, utility power, batteries, etc.) which makes the wiring more hazardous and challenging.

The input and output AC and DC circuits are isolated from the inverter chassis. The inverter system grounding is the responsibility of the installer in accordance with local codes and safety practices.



**WARNING:** Ensure the sources of DC power (i.e., batteries, solar, wind, or hydro) and AC power (utility power or AC generator) are de-energized (i.e., breakers opened, fuses removed) before proceeding – to prevent accidental shock.

### 2.3.1 Protecting Wire - Conduit Box

The AC and DC wires into and out of the inverter must be protected. This can be done by using jacketed wires or by feeding wires through a conduit. Magnum offers for purchase a conduit box (ME-CB) that allows both the AC and DC conduit to be connected to the inverter.



**Info:** If using the ME-CB conduit box, and the AC wires are individual conductors (i.e., not jacketed), the strain reliefs can be removed and replaced with 3/4” grommets.

### 2.3.2 Wiring Requirements

- All conductors that are at risk for physical damage must be protected by tape, or placed in a raceway.
- Always check for existing electrical, plumbing, or other areas of potential damage prior to making cuts in structural surfaces or walls.
- Do not mix AC and DC wiring in the same panel unless specifically approved/designed for both AC and DC wiring. Where DC wiring must cross AC or vice-versa, try to make the wires 90° to one another at the crossing point.
- Both AC and DC overcurrent protection **must** be provided as part of the installation.
- The inverter requires a reliable negative and ground return path directly to the battery.
- Use only copper wires with a minimum temperature rating of 90°C.

### 2.3.3 Wire Routing

Before connecting any wires, determine all wire routes to and from the inverter. Conductors passing through walls or other structural members must be protected to minimize insulation damage, such as chafing. During installation, always avoid placing conductors near sources of chafing caused by vibration or constant rubbing. Typical routing scenarios include:

- AC input wiring from the main AC panel to the inverter
- AC input wiring from a generator (optional) to the inverter
- DC input wiring from the batteries to the inverter
- AC output wiring from the inverter to the AC main panel or to dedicated circuits
- Battery Temperature Sensor cable from the inverter to the batteries
- Remote control cable (optional) to the inverter
- Ground wiring to and from the inverter

## Installation

### 2.3.4 Torque Requirements

- Torque all AC wiring connections to 16 in lbf (1.8 N-m). Torque DC cable connections from 10 to 12 ft lbf (13.6 to 16.3 N-m).

### 2.4 DC Wiring

This section describes the inverter's required DC wire sizes, the recommended disconnect/overcurrent protection, and how to make the DC connections to the inverter and the battery bank.

Refer to Figure 2-4 when connecting the DC wires.



**WARNING:** Even though DC voltage is "low voltage", significant hazards may be present, particularly from short circuits of the battery system.



**CAUTION:** The inverter is NOT reverse polarity protected, which means that if the negative and positive battery voltage is connected backwards to the inverter, the inverter will likely be damaged. You should verify the correct voltage polarity using a voltmeter BEFORE connecting the DC wires.



**CAUTION:** Before wiring the DC cables, review the safety information at the beginning of this manual and the instructions below to ensure a safe and long-lived system.



**Info:** DO NOT connect the battery cables to the inverter until all wiring is complete.

- When the inverter is installed in a Photovoltaic System, standard safety practices require that the DC circuit conductors and overcurrent devices to the inverter be sized to carry not less than 125% of the inverter's maximum current rating.
- The DC positive and negative cables connected to the inverter from the battery bank should be tied together with wire ties or electrical tape approximately every 6 inches (153mm). This helps improve the surge capability and reduces the effects of inductance, which improves the inverter waveform and reduces the wear of the inverter's filter capacitors.
- Use crimped and sealed copper ring terminal lugs to connect the DC wires to the inverter's DC terminals. (We use 5/16" terminal lugs in U.S., determine the European equivalent.)
- The battery bank voltage **must** match the DC voltage required by the inverter (i.e., 24-volt battery bank for a 24-volt inverter), or the inverter may be damaged.
- To ensure the maximum performance from the inverter, all connections from the battery bank to the inverter should be minimized. The exceptions are the DC overcurrent disconnect in the positive line, and a shunt in the negative line. Any other additional connection will contribute to additional voltage drops and these extra connection points may loosen during use.
- All wiring to the battery terminals should be checked periodically (once a month) for proper tightness. The torque requirement for the DC terminals is between 10 to 12 ft lbf (13.6 to 16.3 N-m). If you don't have a torque wrench, ensure all DC terminals are tight and cannot move.
- Be aware that overtightening or misthreading the nuts on the DC terminals can cause the bolts to strip and snap/break off.
- Make sure cables have a smooth bend radius and do not become kinked. Place long cable runs in conduit and follow existing wire runs where possible.
- A brief spark or arc may occur when connecting the battery cables to the inverter DC terminals; this is normal and due to the inverter's internal capacitors being charged.
- Color code the DC cables/wires with colored tape or heat shrink tubing: BROWN for positive (+), BLUE for negative (-), and GREEN (or GREEN w/YELLOW stripe) for DC ground to avoid polarity problems. Refer to Table A-2 for a list of equivalent wiring color codes for Europe and North America.

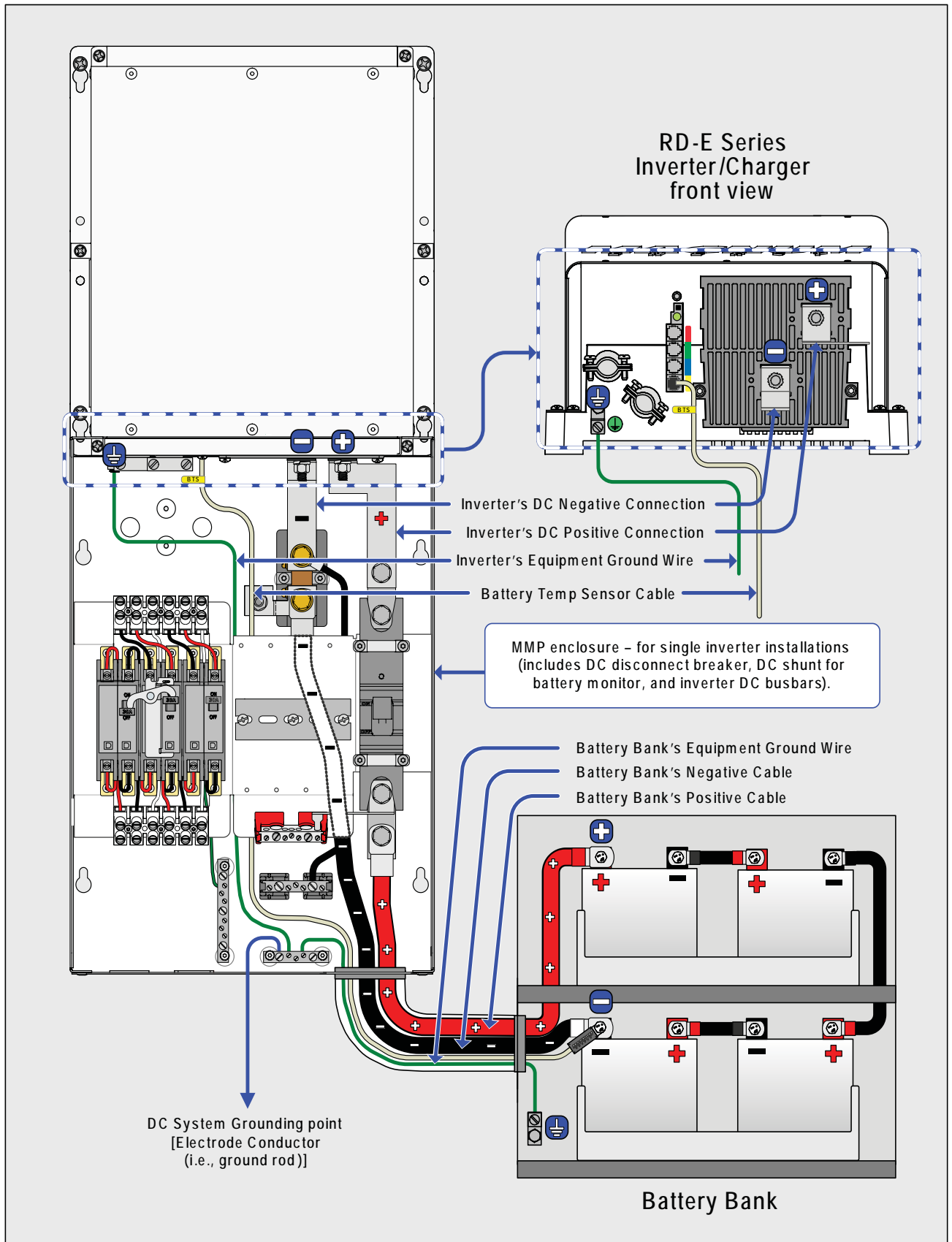

Figure 2-4, DC and Battery Temperature Sensor Wiring

## Installation

### 2.4.1 DC Wire Sizing

It is important to use the correct DC wire to achieve maximum efficiency from the system and reduce fire hazards associated with overheating. Always keep your wire runs as short as practical to help prevent low voltage shutdowns and keep the DC breaker from nuisance tripping (or open fuses) because of increased current draw. See Table 2-1 to select the required minimum DC wire size (and corresponding overcurrent device) based on your inverter model. The cable sizes listed in Table 2-1 for your inverter model are required to reduce stress on the inverter, minimize voltage drops, increase system efficiency, and ensure the inverter's ability to surge heavy loads.

If the distance from the inverter to the battery bank is greater than 5 feet (1.5 m), the DC wire size will need to be increased. Longer distances cause an increase in resistance, which affects the performance of the inverter. Continue to use the overcurrent device previously determined from Table 2-1, and then refer to Table 2-2 to determine the minimum DC wire size needed for various distances based on your inverter model.

### 2.4.2 DC Overcurrent Protection

DC overcurrent protection is not included in the inverter, it **must** be provided as part of the installation. This requirement is needed in order to comply with electrical code regulations and for safety reasons. The DC overcurrent protection device must be installed in the positive DC cable line, it can be a fuse or a circuit breaker, and it must be DC rated. It must be correctly sized according to the size of DC cables being used, which means it is required to open before the cable reaches its maximum current carrying capability, thereby preventing a fire. The NEC requires both overcurrent protection and a disconnect switch. If a circuit breaker is used as the overcurrent protection device, it can also be used as the required DC disconnect.

If a fuse is used as an overcurrent device, a Class-T type or equivalent is recommended. This fuse type is rated for DC operation, can handle the high short-circuit currents, and has a time delay that allows for momentary current surges from the inverter without opening the fuse. However, because the fuse can be energized from both directions, if it is accessible to unqualified persons the NEC requires that it be installed in such a manner that the power must be disconnected on both ends of the fuse before servicing.

The recommendations in Table 2-1 may not meet all local code requirements.

**Table 2-1, Recommended DC Wire/Overcurrent Device for Rated Use**

Inverter Model	Maximum Continuous Current <sup>1</sup>	Using Conduit		DC Grounding Electrode Wire Size <sup>4</sup>
		Minimum DC Wire Size (90°C rating) <sup>2</sup>	Maximum DC Breaker Size <sup>3</sup>	
RD2624E	173 amps	#4/0 AWG [107.2 mm <sup>2</sup> ] (260 amps)	250 amps	#6 AWG (13.3 mm <sup>2</sup> )
RD4024E	267 amps	#4/0 AWG [107.2 mm <sup>2</sup> ] (260 amps)	250 amps <sup>5</sup>	#6 AWG (13.3 mm <sup>2</sup> )

Note 1 - Maximum Continuous Current is based on the inverter's continuous power rating at the lowest input voltage with an inefficiency factor.

Note 2 - Wire size is based on the requirements needed to increase efficiency and reduce stress to the inverter.

Note 3 - The next larger standard size overcurrent device may be used if the de-rated cable ampacity falls between the standard recommended overcurrent devices.

Note 4 - As recommended, the DC grounding electrode conductor can be a #6 AWG (33.6 mm<sup>2</sup>) conductor if that is the only connection to the grounding electrode and that grounding electrode is a rod, pipe, or plate electrode.

Note 5 - May not allow continuous operation at full rated power.

**Table 2-2, DC Wire Size For Increased Distance**

Inverter Model	Minimum Recommended DC Wire Size (one way) *					
	5 feet (1.5m) or less		5 to 10 feet (1.5-3m)		10-15 feet (3-4.5m)	
	In Conduit	In Free Air	In Conduit	In Free Air	In Conduit	In Free Air
RD2624E	#4/0 AWG (107.2 mm <sup>2</sup> )	#2/0 AWG (67.4 mm <sup>2</sup> )	#4/0 AWG x2 (107.2 mm <sup>2</sup> x2)	#4/0 AWG (107.2 mm <sup>2</sup> )	not recommended	#4/0 AWG x2 (107.2 mm <sup>2</sup> x2)
RD4024E	#4/0 AWG (107.2 mm <sup>2</sup> )	#4/0 AWG (107.2 mm <sup>2</sup> )	#4/0 AWG x2 (107.2 mm <sup>2</sup> x2)	#4/0 AWG x2 (107.2 mm <sup>2</sup> x2)	not recommended	#4/0 AWG x2 (107.2 mm <sup>2</sup> x2)

\* Copper wire rated with 90°C (194°F) insulation at an ambient temperature of 30°C (86°F).

**2.4.3 DC Cable Connections**

Do not put anything between the DC cable ring lug and the battery terminal post or the flat metal part of the inverter’s DC terminal. When connecting the DC cable to the battery or inverter DC terminals, the cable should be placed directly against the inverter or battery terminals. Incorrectly installed hardware causes a high resistance connection, which could lead to poor inverter/charger performance and may melt the cable and terminal connections.

Follow the examples in Figures 2-5 and 2-6 to connect the DC cables and stack the hardware correctly. Tighten the terminal connections from 10 to 12 ft lbf (13.6 to 16.3 N-m).



**CAUTION:** The DC terminal and Kep nuts are made of stainless steel, which has a high likelihood of seizure. To help prevent the bolt and nut from seizing — causing the bolts to strip or snap/break-off — the use of anti-seize lubricant is highly recommended.



**Info:** If antioxidant grease or spray is used, apply it after all the connections have been made and are properly tightened.



**Info:** A 1/2-inch wrench or socket is used to tighten the 5/16 SAE Kep nuts.

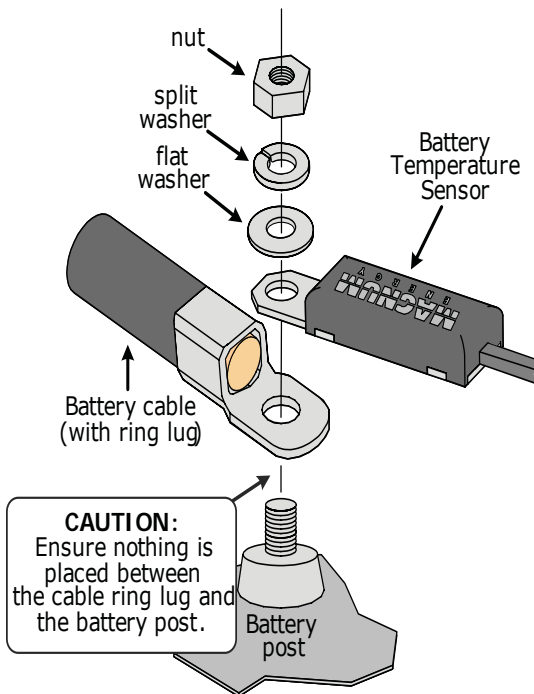

**Figure 2-5, Battery Hardware Installation**

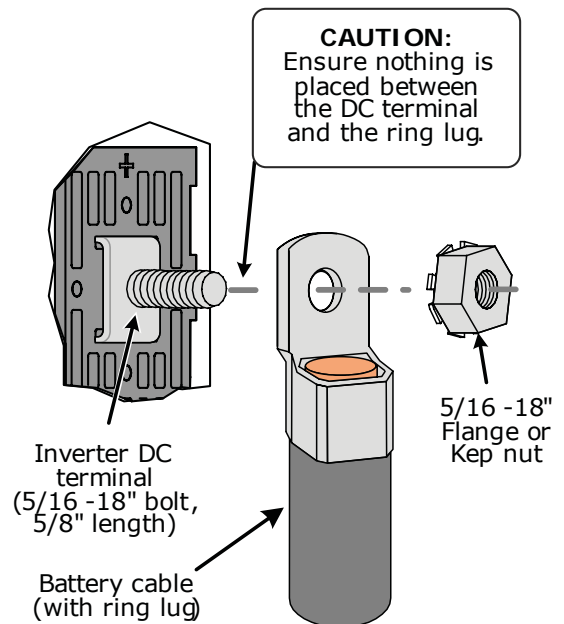

**Figure 2-6, Inverter DC Hardware Installation**

## Installation

### 2.4.4 Wiring the Battery Bank



**WARNING:** Lethal currents will be present if the positive and negative cables attached to the battery bank touch each other. During the installation and wiring process, ensure the cable ends are insulated or covered to prevent touching/shorting the cables.



**Info:** DO NOT connect the DC wires from the battery bank to the inverter until: 1) all DC and AC wiring are completed, 2) the correct DC and AC overcurrent protection have been installed, and 3) the correct DC voltage and polarity have been verified.



**Info:** For the RD-E Series inverter/charger to perform optimally, a minimum battery bank of 200 AH is recommended for moderate loads (<1000W) and greater than 400 AH for heavy loads ( $\geq 1000W$ ).

Depending upon the voltage of the batteries you use (6 or 12 VDC), the batteries must be wired in series, parallel, or series-parallel to provide the correct voltage (see Appendix B - Battery Information for guidance on wiring batteries together). The interconnecting DC wires must be sized and rated exactly the same as those that are used between the battery bank and the inverter.

Place the batteries as close as practical to the inverter, preferably in an insulated and ventilated enclosure. Allow adequate space above the batteries to access the terminals and vent caps (as applicable). Also, allow at least 1" (2.5 cm) of space between the batteries to provide good air flow. DO NOT mount the batteries directly under the inverter.



**CAUTION:** Install batteries in a well ventilated area. Batteries can produce explosive gases. For compartment/enclosure installations, always vent batteries to the outside.



**Info:** To ensure the best performance from your inverter system, batteries should be of the same size, type, rating, and age. Do not use old or untested batteries.

### 2.4.5 Battery Temperature Sensor Installation and Wiring

The Battery Temperature Sensor (see Figure 2-7) provides the inverter with precise battery temperature information to automatically adjust the ABSORB and FLOAT charge voltage set-points. This enables the batteries to be correctly charged under extreme temperature changes. If the temperature sensor is NOT installed and the batteries are subjected to large temperature changes, battery life may be shortened.

The BTS provided may be extended to a maximum length of 40' (12 m) using a RJ11 connector (female to female) and a standard phone cable with RJ-11 connectors. However, your inverter to battery cable length shouldn't exceed the recommended distance shown in Table 2-2.

#### To install the BTS:

1. Attach the ring terminal end of the Battery Temperature Sensor to the negative battery terminal; see Figure 2-5 for proper connection to the battery terminal.
2. Route the sensor's cable to the inverter following existing wire runs.
3. Connect the RJ11 connector end of the BTS cable to the yellow-labeled BTS Port on the inverter (see Figure 1-1, Item 6).

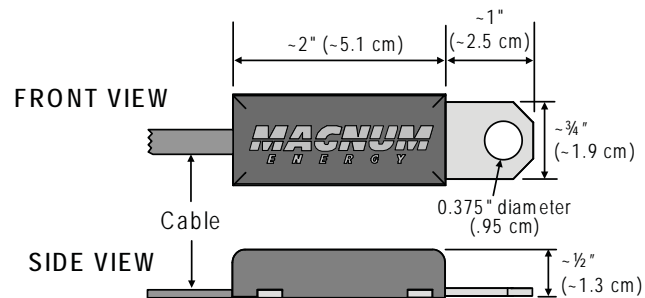

**Figure 2-7, Battery Temperature Sensor**

### 2.4.6 Wiring the Inverter to the Battery Bank



**CAUTION:** The inverter is NOT reverse polarity protected. If this happens, the inverter will be damaged and will not be covered under warranty. Before connecting the DC wires from the batteries to the inverter, verify the correct battery voltage and polarity using a voltmeter. If the positive terminal of the battery is connected to the negative terminal of the inverter and vice versa, severe damage will result. If necessary, color code the cables (with colored tape); red for positive (+), and marked white for negative (-) to avoid polarity confusion.



**Info:** The DC overcurrent device (e.g., circuit breaker or fuse) must be placed in the positive (brown) DC cable line between the inverter's positive DC terminal and the battery's positive terminal; as close to the battery as possible.

#### DC Ground Wire

Route an appropriately sized DC grounding wire (green or bare wire) from the inverter's DC Equipment Ground Terminal (see Figure 1-2, Item 7) to a dedicated system ground. Recommended tightening torque is 45 in lbf (5.1 N-m). Refer to Section 2.6 for grounding information and sizing the DC ground wires.

#### DC Negative Wire

Route an appropriately sized DC negative wire (marked blue) from the negative terminal of the battery bank to the inverter's Negative DC Terminal (see Figure 1-2, Item 11).



**Info:** If installing a battery monitor such as Magnum's ME-BMK, install a DC shunt in-line with the negative battery cable.

#### DC Positive Wire

Mount the circuit breaker or fuse assembly as near as practical to the batteries and leave open (i.e., no power to inverter).



**WARNING:** DO NOT close the DC circuit breaker or connect the fuse to connect battery power to the inverter at this time. This will occur in the **Functional Test** after the installation is complete.



**CAUTION:** If connecting live battery cables to the inverter DC terminals, a brief spark or arc may occur; this is normal and due to the inverter's internal capacitors being charged.

Route and connect an appropriately sized DC positive wire (brown) from the inverter's Positive DC Terminal (see Figure 1-2, Item 10) to one end of the circuit breaker (or DC fuse block).

Connect a short wire (same rating as the DC wires) to the other side of the DC circuit breaker (or one end of the fuse/disconnect assembly), and the other end of the short wire to the positive terminal of the battery bank (see Figure 2-1 for reference). This is essential to ensure even charging and discharging across the entire battery bank.

Ensure the DC wire connections (on the batteries, inverter, and DC circuit breaker/fuse lugs) are flush on the surface of the DC terminals, and the hardware (lock washer and nut) used to hold these connections are stacked correctly (Figures 2-5 and 2-6). Verify all DC connections are torqued from 10 to 12 ft lbf (13.6 to 16.3 N-m).

Once the DC connections are completely wired and tested, coat the terminals with an approved anti-oxidizing spray.

Attach the red and black terminal covers over the inverter's DC connectors, and then secure them in place with the supplied screws.

If the batteries are in an enclosure, perform a final check of the connections to the battery terminals, and then close and secure the battery enclosure.



## Installation

### 2.5 AC Wiring

This section provides information on how to make the AC connections to the inverter using the correct AC wire size and the corresponding overcurrent protection.

#### 2.5.1 Pre-AC Wiring Requirements



**CAUTION:** Before installing any AC wiring, review the safety information and cautionary markings at the beginning of this manual and the directions below to ensure a safe and long-lived system:

- Read all instructions and cautionary markings located at the beginning of this manual and in the Pre-installation section before installing the inverter and batteries.
- Always use properly rated circuit-breakers. If using an electrical sub-panel, circuit breakers can only be moved from the main electrical panel to the sub-panel if the breakers are also listed to be installed in the sub-panel.
- AC wiring must be no less than #12 AWG (3.3 mm<sup>2</sup>) gauge copper wire and be approved for the application (i.e., renewable energy systems).
- DO NOT connect the inverter's output to an AC power source. This could cause severe damage to the inverter and is not covered under warranty.



**WARNING:** To reduce the risk of fire, do not connect this inverter to an AC load center (circuit breaker panel) having multi-wire branch circuits connected.

#### 2.5.2 AC Wire Size and Overcurrent Protection

The AC input and output wiring must be sized per the local electrical safety code requirements to ensure the wire's ability to safely handle the inverter's maximum load current. After determining the proper AC wire sizes, they are required to be protected from short circuits and overloads by an overcurrent protection device, and have a means to disconnect the AC circuits.

The RD-E Series allows the AC input and output wiring to be permanently wired. The inverter's input is wired to the service/distribution panel (main panel). The inverter's output is then wired to a dedicated panel (sub-panel). The inverter uses the circuit breakers provided in the panels as the overcurrent protection and the AC disconnect device.

AC overcurrent protection isn't included in the inverter and **must** be provided as part of the inverter installation. The AC overcurrent protection device must be a circuit breaker or a fuse/disconnect, be properly sized, and be branch circuit rated for the wire it's protecting and the appliances being powered.

When in Standby mode, the full AC continuous pass-thru capacity of the RD-E Series inverter/charger is 30 amps. For a 30 amp continuous pass-thru capability, each AC LINE IN input to the inverter requires a 30 amp continuous duty rated breaker<sup>1</sup>, which corresponds to a minimum cable size of #10 AWG<sup>2</sup> (5.3 mm<sup>2</sup>) in conduit. If you are using other circuit breakers/wire sizes, refer to the appropriate electrical codes for proper sizing requirements.



**CAUTION:** The inverter's internal AC transfer relay contacts are rated for 30 amps per leg, the pass-thru current must be no greater than 30 amps per leg or damage to this relay may occur.

Note 1 - The breaker must be de-rated by 80% if not rated for continuous duty. Circuits are not to be operated continuously at more than 80% of rating unless listed with a 100% continuous rating.

Note 2 - Copper wire should be rated with 90° C insulation at an ambient temperature of 30° C (86 °F).



Figure 2-8, RD-E Series Inverter/Charger - AC Wiring

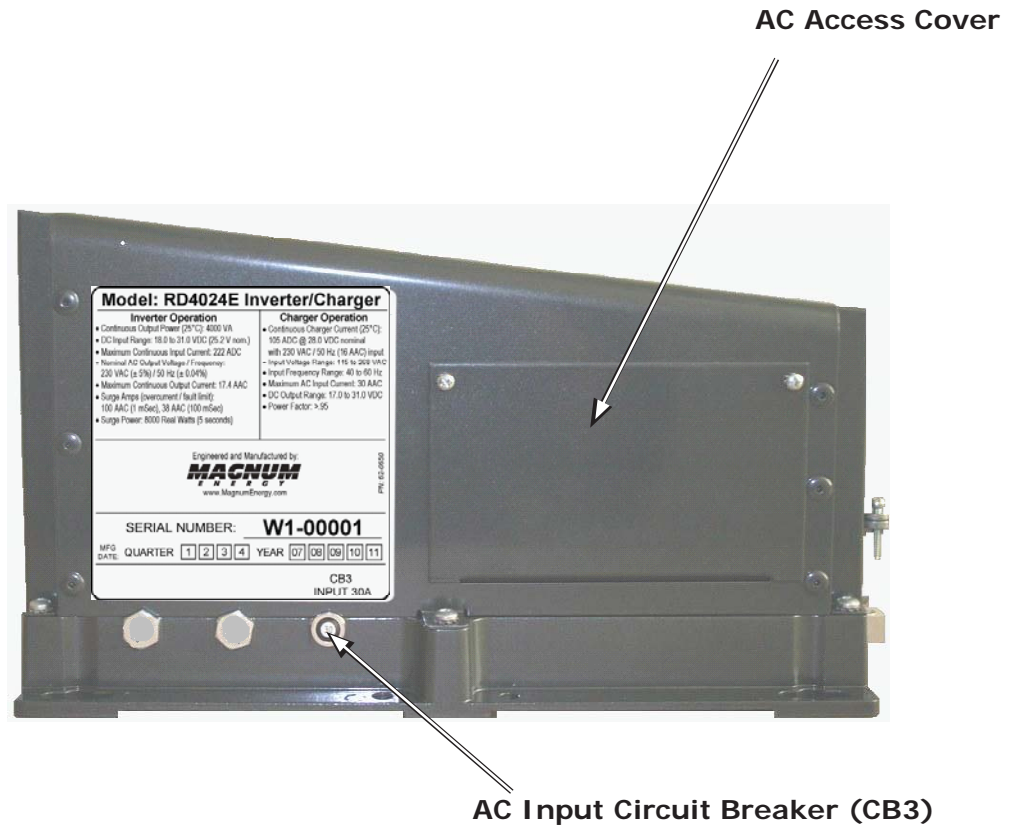

Figure 2-9, RD-E Series Inverter/Charger - AC Wiring (Access Cover)

## Installation

### 2.5.3 AC Terminal Block Connections

The inverter has a four-pole AC terminal block and one AC ground terminal to connect the inverter's AC input and output wiring. To access and view the AC terminal block and ground terminal, remove the two Phillips screws holding the AC Access Cover plate (see Figure 1-3, Item 15).

Each connection on the AC terminal block is rated to accept one #14 to #6 AWG (2.1 to 13.3 mm<sup>2</sup>) CU stranded wire, or two #12 AWG (3.3 mm<sup>2</sup>) CU stranded wires. The connection uses a M3.5 slotted head screw, and the maximum tightening torque is 16 in lbf (1.8 N-m).



**Info:** For alternative energy installations and to comply with standard safety requirements, the four-pole AC terminal is provided with a stainless steel wire protector to prevent wire damage from the set-screw.



**Info:** The inverter's NEUT IN and NEUT OUT terminals are connected together internally.

The AC ground terminal can accept one #14 to #6 AWG (2.1 to 13 mm<sup>2</sup>) CU stranded wire. It uses a slotted head screw and has a recommended maximum tightening torque of 45 in lbf (5.1 N-m). For multiple ground wires, use a pressure or mechanical connector to attach the single wire from the AC ground terminal to the input and output ground connections.

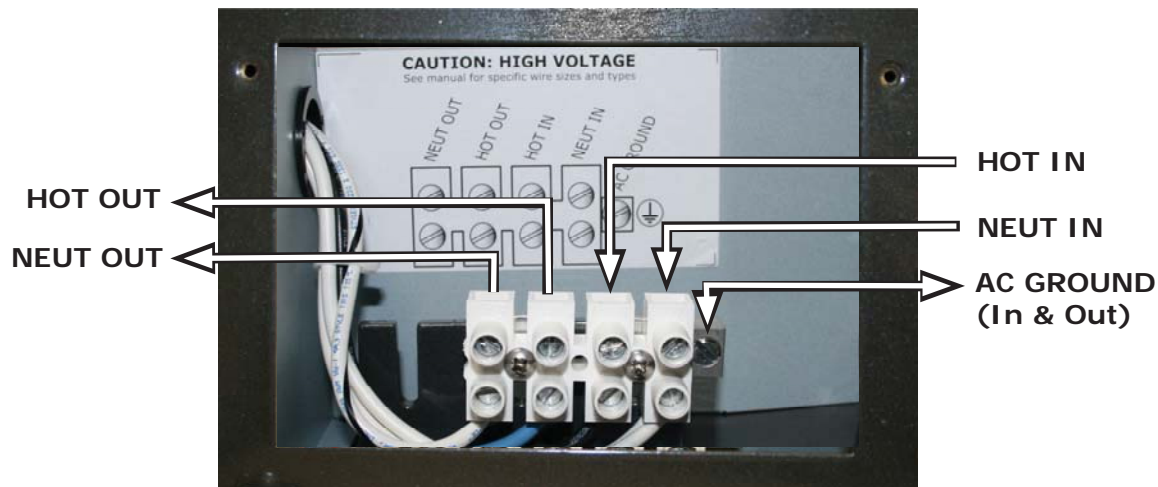

*Figure 2-10, AC Terminal Block*

### 2.5.4 AC Conductor Wiring

The following steps are basic guidelines for installing and connecting the AC wiring into and out of the inverter. Refer to Section 2.5.5 and Figure 2-11 before beginning.



**WARNING:** Before making any AC connections, make sure the inverter is disconnected from the battery and there is no other source of live power connected to the inverter.

#### Wiring the Inverter AC Input

1. Remove the two Phillips screws on the AC Access Cover (see Figure 1-3, Item 15) to access the internal AC Terminal Block (see Figure 2-10).
2. Route the cable from the AC electrical main panel through one of the strain relief clamps to the AC INPUT. Tighten the strain relief clamp securely on the cable. Always leave a little extra slack in the wiring.
3. Connect the LINE IN (brown) from the main panel's dedicated breaker to the "HOT IN" terminal. Tighten the "HOT IN" terminal to 16 in lbf (1.8 N-m).
4. Connect the NEUTRAL IN (blue) from the main panel's neutral busbar to the "NEUT IN" terminal. Tighten the "NEUT IN" terminal to 16 in lbf (1.8 N-m).

#### Wiring the Inverter AC Output

1. Route the cable from the inverter's AC OUTPUT to the AC electrical sub-panel through the strain relief clamp. Tighten the strain relief clamp securely on the cable.
2. Connect the LIVE OUT (brown) wire from the "HOT OUT" terminal to the sub-panel main breaker. Tighten the "HOT OUT" terminal to 16 in lbf (1.8 N-m).
3. Connect the NEUTRAL OUT (blue) from the "NEUT OUT" terminal to the sub-panel's neutral busbar. Tighten the "NEUT OUT" terminal to 16 in lbf (1.8 N-m).

#### Wiring the Inverter AC Ground

1. Combine the ground (green w/yellow stripe) wire from the main panel's ground busbar and the ground (green w/yellow stripe) wire from the sub-panel's ground busbar. After these grounds are combined, connect them to the "AC GROUND" terminal. Tighten the "AC GROUND" terminal to 16 in lbf (1.8 N-m).

#### AC Wiring Inspection

1. Verify all cable runs are secured.
2. Verify strain reliefs or grommets are in place to prevent damage to the wiring or conduit where it passes through walls or other openings.
3. After verifying all AC connections are correct and all inverter AC terminal screws are torqued to 16 in lbf (1.8 N-m), replace the AC wiring access cover and the covers on the main electrical/distribution panel.

### 2.5.5 AC Wiring Configuration

The wiring configuration for installing and connecting the AC conductors into and out of the inverters (RD2624E & RD4024E models) requires an AC source<sup>1</sup> of 230VAC @ < 30 amps. The maximum input breaker required is 30A (single pole), and the minimum wire size is #10 AWG/5.3 mm<sup>2</sup> (In & Out). The maximum inverter pass-thru capacity is 3600W (30A @ 230VAC). Refer to the wiring diagram in Figure 2-11.

*Note 1: AC Source is from either the utility/grid power or an AC generator.*

# Installation

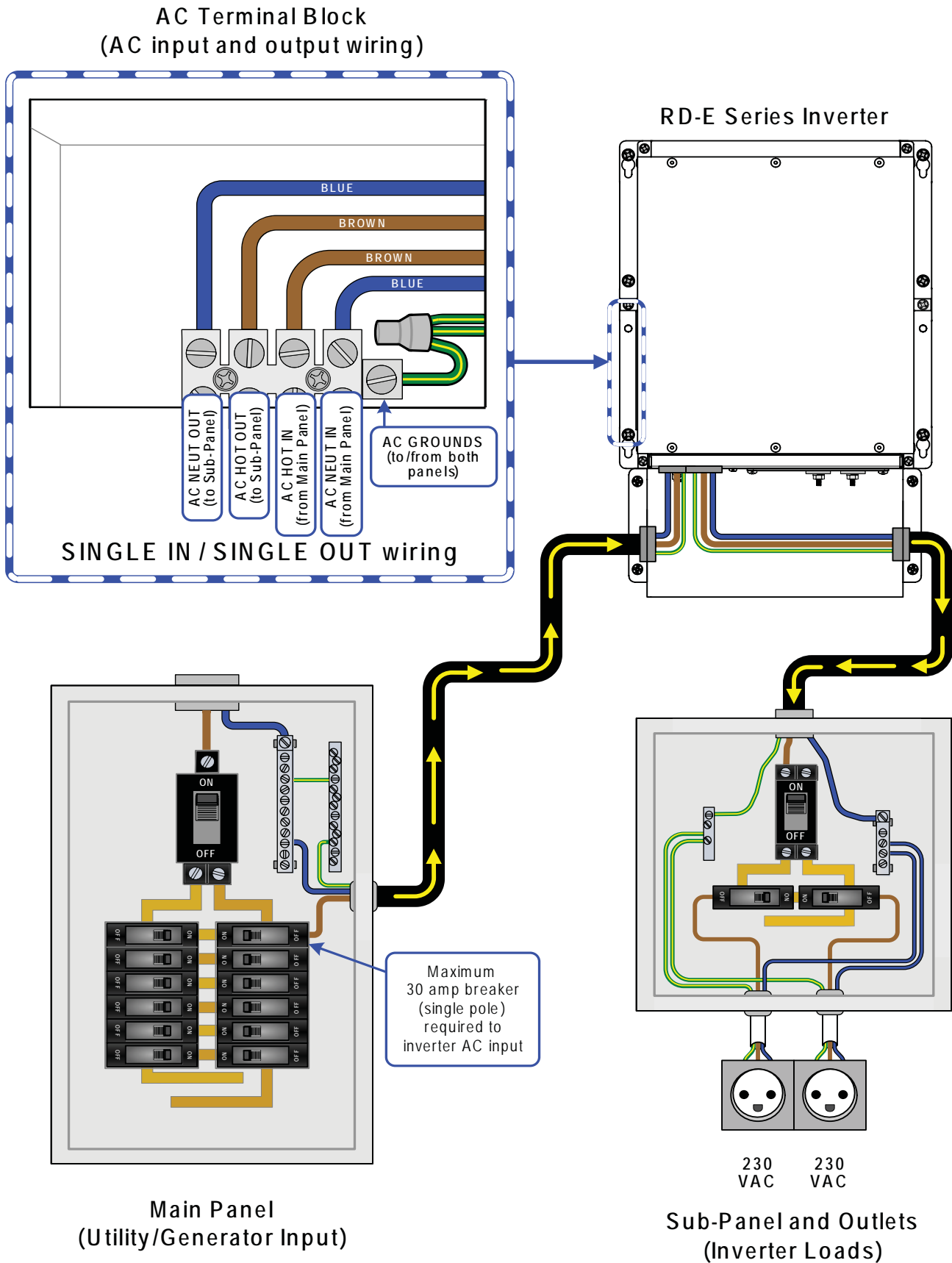

Figure 2-11, AC Wiring Input/Output

## 2.6 Grounding Inverters

The inverter/charger should always be connected to a permanent, grounded wiring system. An inverter system that is properly grounded will limit the risk of electrical shock, reduce radio frequency noise from the inverter and minimize excessive surge voltages induced by lightning. This is done by ensuring there is a well-defined, very low-resistance path from the electrical system to the grounding system. This low-resistance path helps stabilize the electrical system voltage with respect to ground and carries fault currents directly to ground if the electrical system malfunctions.

To understand how the conductors in the electrical circuit will be connected to the system ground, the following terms should be understood:

- **Grounded Conductor (GC):** The wire/cable in the electrical system that normally carries current (usually the AC neutral and/or the DC negative); and is intentionally connected or “bonded” to the ground system. This wire or the ends of this wire should be colored white or gray.
- **Equipment Grounding Conductor (EGC):** A wire/cable that does not normally carry current and is used to connect the exposed metal parts of equipment that might be accidentally energized to the grounding electrode system or the grounded conductor. This wire or the ends of this wire should be green or green with a yellow stripe; or this wire can be bare copper.
- **Grounding Electrode Conductor (GEC):** The wire/cable that does not normally carry current and connects the grounded conductor and/or the equipment grounding conductor to the grounding electrode at the service equipment.
- **Grounding Electrode (GE):** A ground rod or conducting element that establishes an electrical connection to the earth.
- **System Bonding Jumper (SBJ):** The connection between the grounded circuit conductor in the electrical system and the equipment grounding conductor at a separately derived system.

The RD-E Series inverter/charger uses both AC and DC power; however, the AC electrical system is isolated from the DC electrical system by an internal transformer. Although this inverter/charger has two electrical systems, each electrical system **must** be properly grounded and connected to a common “earth” reference (refer to Figure 2-12).

For proper grounding, each electrical system must connect all exposed metal parts of equipment (via Equipment Grounding Conductors - EGC) and one of the current-carrying conductors (Grounded Conductor - GC) together at a common point (Ground Busbar - GBB), usually by a System Bonding Jumper (SBJ) in an electrical service disconnect panel. The common point of each electrical system is then connected (via Grounding Electrode Conductor - GEC) to the common ground reference, such as a ground rod (Grounding Electrode - GE). This connection to earth should only be made at one point in each electrical system; otherwise, parallel paths will exist for the currents to flow. These parallel current paths would represent a safety hazard and are to be avoided during installation.

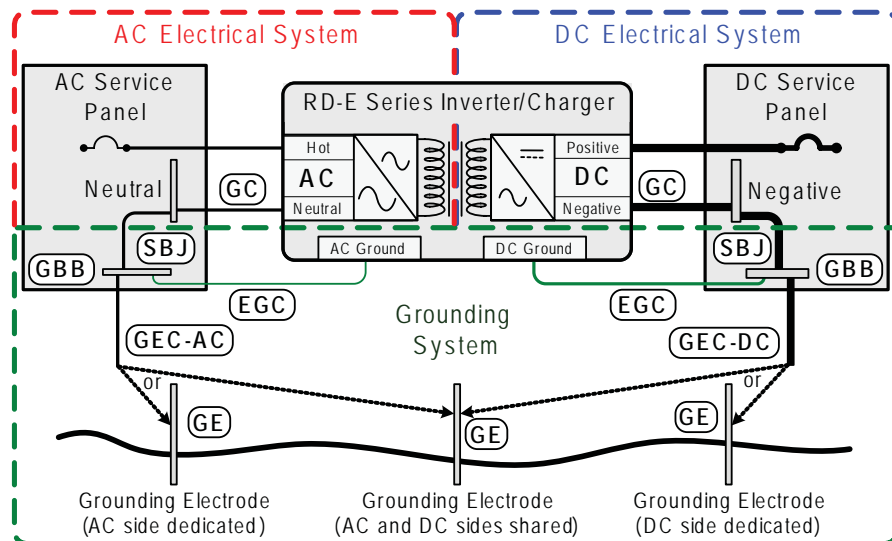

**Figure 2-12, Grounding System for RD-E Series**

## Installation

### 2.6.1 Sizing the Grounding Electrode Conductors

**AC Side** - The size of the AC Grounding Electrode Conductor (GEC -AC) depends on the size of the largest ungrounded conductor feeding the AC load center. One #8 AWG (8.4 mm<sup>2</sup>) copper conductor will serve as an AC Grounding Electrode Conductor (GEC -AC) for AC power conductors smaller than and including #2 AWG (33.6 mm<sup>2</sup>) copper. See Table 2-4 for additional values.

**Table 2-3, AC Grounding Electrode Conductor Sizing**

Size of Largest Ungrounded Conductor	Minimum Size of Grounding Electrode Conductor
#2 AWG (33.6 mm <sup>2</sup> ) or smaller	#8 AWG (8.4 mm <sup>2</sup> )
#1 to #1/0 AWG (42.4 to 53.5 mm <sup>2</sup> )	#6 AWG (13.3 mm <sup>2</sup> )
#2/0 or #3/0 AWG (67.4 or 84.97 mm <sup>2</sup> )	#4 AWG (21.1 mm <sup>2</sup> )
Over #3/0 AWG (84.97 mm <sup>2</sup> ) thru 350 kcmil	#2 AWG (33.6 mm <sup>2</sup> )

**DC Side** - To size the DC grounding electrode conductor, you must first determine which one of the following three methods will be used to connect the DC and AC grounding points in the inverter's two electrical systems to the common "earth" ground:

**Method 1 (see Figure 2-13):** This method uses a separate grounding electrode for the DC system and the AC system. In this method — since there are multiple connections to the DC Grounding Electrode (GEC - DC) — the size of the DC grounding electrode conductor cannot be smaller than the largest conductor in the DC system (usually the battery-to-inverter cable).

The DC Grounding Electrode (GE - DC) must be bonded to the AC Grounding Electrode (GE - AC) to make a grounding system; this bonding conductor (BC) cannot be smaller than the largest grounding electrode conductor, either AC or DC.

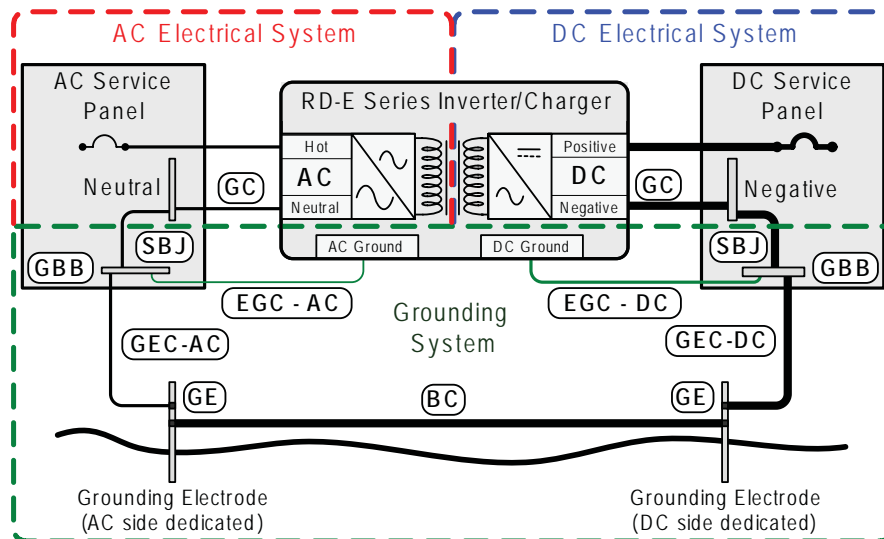

**Figure 2-13, Multiple Connections to DC Ground Rod (Method 1)**

**Method 2 (see Figure 2-14):** When the AC and DC service panels are near each other, then the AC Grounding Electrode Conductor (GEC – AC) and DC Grounding Electrode Conductor (GEC – DC) can be connected to a single grounding electrode. In this method – since there are multiple connections to the DC Grounding Electrode (GEC – DC) – the size of the DC grounding electrode conductor can not be smaller than the largest conductor in the DC system (usually the battery-to-inverter cable).

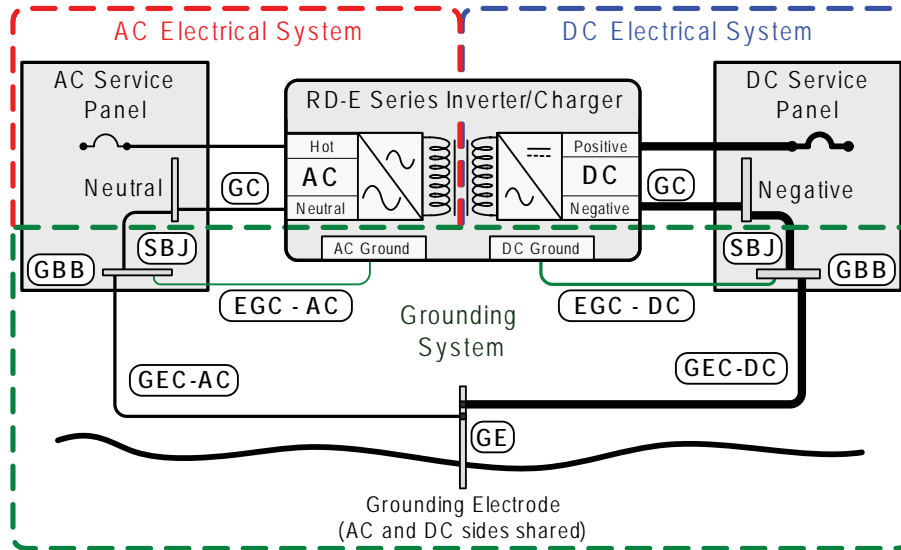

**Figure 2-14, Multiple Connections to DC Ground Rod (Method 2)**

**Method 3 (see Figure 2-15):** The AC Grounding Electrode Conductor (GEC – AC) is bonded to the DC ground point and the DC Grounding Electrode Conductor (GEC – DC) is the *only connection* to the grounding electrode, which must be a rod, pipe, or plate electrode.

In this method, since there is only one connection to the ground rod, the DC grounding electrode conductor is not required to be larger than #6 AWG (13 mm<sup>2</sup>) copper. The reasoning for allowing this smaller grounding electrode conductor is that it is only required to stabilize the system voltage with respect to earth and the other properly sized conductors in each electrical system will safely carry any fault currents if they occur.

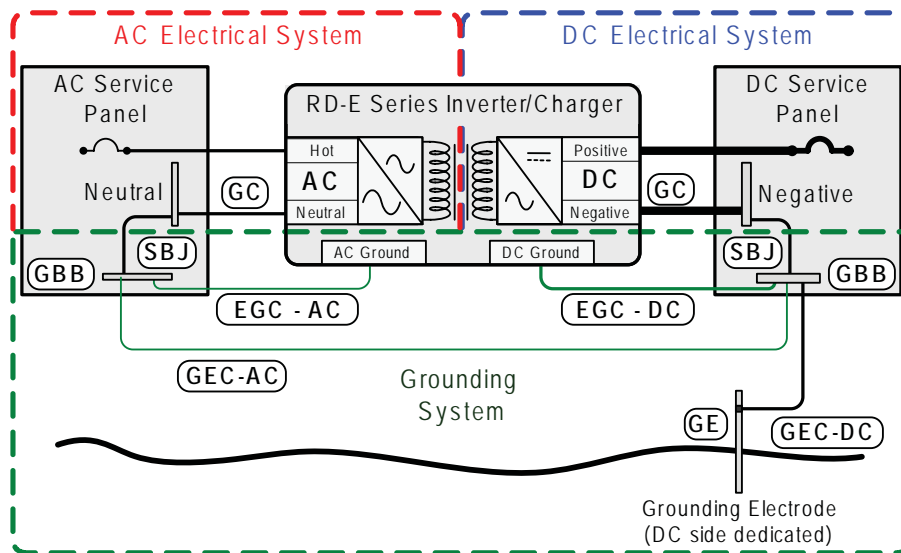

**Figure 2-15, Single Connection to DC Ground Rod (Method 3)**



## Installation

### 2.6.2 System Bonding Jumper

The RD-E Series inverter does not include an internal bond between the grounded conductor (AC neutral/DC negative) and the equipment grounding terminals. This bond [System Bonding Jumper (SBJ)] is usually done in the main distribution panel for each electrical system.



**CAUTION:** There should be one and only one point in each electrical system (both AC and DC) where the grounded conductor is attached to the grounding electrode conductor.

**AC Side** - The size of the System Bonding Jumper (SBJ) in the AC electrical system is based on the area of the largest AC ungrounded conductor. In accordance with the NEC, use Table 2-3 to determine the system bonding jumper size compared to the largest AC ungrounded conductor.

**DC Side** - The size of the System Bonding Jumper (SBJ) in the DC electrical system must not be smaller than the DC Grounding Electrode Conductor (GEC - DC) used, which is determined from the grounding method that will be used (see Section 2.6.1).

### 2.6.3 Equipment Grounding Conductor

The inverter case and all other non-current carrying exposed metal surfaces in the entire electrical system that may be accidentally energized must be grounded. The equipment grounding conductor must be sized to safely carry the maximum ground-fault current likely to be imposed on it from where a ground-fault may occur. In accordance with standard practices, use Table 2-4 to size the equipment grounding conductors. This table requires that the equipment grounding conductor be sized according to the rating of the overcurrent device protecting the circuit.



**CAUTION:** The connections and wiring for the equipment grounding conductor must be continuous to allow fault currents to properly operate overcurrent devices. Where equipment is removed and this disconnects the bonding connection between the grounding electrode conductor and exposed conducting surfaces, a bonding jumper must be installed while the equipment is removed.

**AC Side** - Where the AC output from the inverter is connected to an AC load center, there should be an equipment grounding conductor connected between the inverter case and the grounding point in the AC load center. The AC Equipment Grounding Conductor (EGC - AC) is sized per Table 2-4 and is connected to the inverter's AC equipment grounding terminal shown in Figure 2-10.

**DC Side** - Since the currents on the DC side are higher than the AC side (5 times at 24 volts), the equipment grounding needs are different. The DC Equipment Grounding Conductor (EGC - DC) is sized per Table 2-4 and connected to the DC equipment grounding terminal on the inverter shown in Figure 1-2 (Item 7).

**Table 2-4, Equipment Grounding Conductor Sizing**

Rating of Overcurrent Device	Minimum Size of Copper Ground Wire
15 amp	#14 AWG (2.1 mm <sup>2</sup> )
20 amp	#12 AWG (3.3 mm <sup>2</sup> )
30 - 60 amp	#10 AWG (5.3 mm <sup>2</sup> )
100 amp	#8 AWG (8.4 mm <sup>2</sup> )
200 amp	#6 AWG (13.3 mm <sup>2</sup> )
300 amp	#4 AWG (21.1 mm <sup>2</sup> )
400 amp	#3 AWG (26.6 mm <sup>2</sup> )

## 2.7 Inverter Notification Requirements

When an inverter is installed in a building, facility, or structure, standard safety practices require a label or plaque be present. This label/plaque is required to be readily visible and provide information that informs personnel to the location of all electrical system disconnects. This is to ensure all power to a building is quickly located and shut down in an emergency. There are also specific requirements for this label/plaque depending on the inverter application, they are:

### 2.7.1 Facilities with Standalone Systems

Any building, facility, or structure with a photovoltaic power system that is not connected to a utility service source and is a standalone system, must have a permanent plaque or directory installed on the exterior of the building or structure at a readily visible location acceptable to the Authority Having Jurisdiction (AHJ). The plaque or directory must provide the location of the system disconnecting means, and include information regarding whether the structure contains a standalone electrical power system.

### 2.7.2 Inverter Warning Label

A warning label as shown in Figure 2-16 is provided to inform all personnel that an inverter is installed in your electrical system. Affix this label in a clearly visible location by the electrical panel that is being powered by the inverter. This is because it might be falsely assumed that the panel is no longer "hot" after the AC power has been shut off, when power may actually still be available due to the inverter automatically powering the panel.

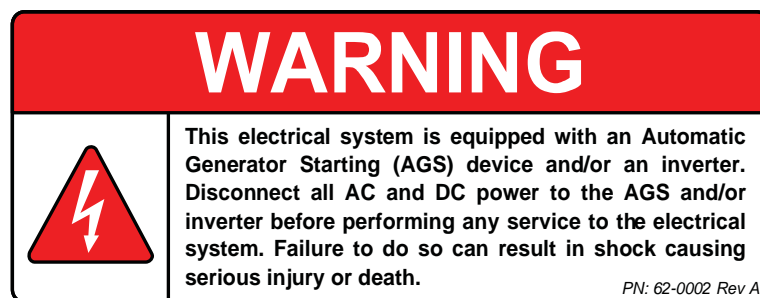

*Figure 2-16, Warning Label*

## 2.8 Final Inspection

1. Verify all cables/conduit runs are secured with wire ties or other non-conductive fasteners to prevent chafing, or damage from movement and vibration.
2. Verify strain reliefs or grommets are in place to prevent damage to the wiring or conduit where it passes through walls or other openings.
3. Verify all AC connections are correct and torqued to a maximum of 16 in lbf (1.8 N-m).
4. Replace the covers on the main electrical/distribution panel.
5. Replace the chassis access cover.
6. Verify the inverter's front panel switch is in the OFF position.



**Info:** If required by code, have the installation inspected by an electrical inspector.

## Installation

### 2.9 Functional Test

After all electrical connections to the inverter, batteries, AC source, and sub-panel have been completed, follow these steps to test the installation and the inverter operation.



**CAUTION:** Use a multimeter to verify the correct DC voltage for your particular inverter model (i.e., 24-volt battery bank for a 24-volt inverter), and to ensure the polarity of the battery voltage is correct (battery positive connected to inverter positive terminal, and battery negative connected to inverter negative terminal).

1. Apply battery power to the inverter by closing the DC circuit breaker or inserting a fuse. The inverter will remain OFF, but the green status indicator on the front of the inverter will quickly blink once to indicate that DC power has been connected and is ready to be turned on.
2. Prior to turning on the inverter, make sure all AC loads (e.g., appliances) are NOT connected to the inverter's output or to any AC outlets powered by the inverter.
3. Lightly press and release the inverter's ON/OFF switch to turn the inverter ON. Verify the inverter's status indicator is blinking – indicating the inverter is ON.
4. Connect a small light bulb *no larger than 75 watts* to the inverter output and verify it comes on and shines normally. DO NOT connect anything but a light bulb until all wiring and voltages are confirmed to be correct.



**Info:** The inverter's AC output voltage will not be correct until a load greater than 5 watts (5 watts is the default setting) is connected to the inverter; or, when the Search mode is turned OFF with a remote display (ME-RC50 or ME-ARC50).

5. Check the AC output voltage of the inverter by connecting an AC voltmeter to the output terminals (see Figure 2-17) and verify the correct output voltages.
6. Press and release the inverter's ON/OFF switch to turn the inverter off. The inverter's status indicator and the connected load should go off.
7. Apply AC power to the inverter's AC input. After the AC input power is qualified (approximately 15 seconds), the incoming AC power will transfer through the inverter to the inverter's AC output and power the light bulb. Verify the inverter's status indicator and that the light bulb comes on.
8. Even though the light bulb is on, the inverter is currently disabled (off). Press and release the ON/OFF switch on the inverter to enable (turn-on) the inverter.
9. Disconnect the incoming AC power to the inverter. Verify the light bulb remains on and is now powered by the inverter.

If the inverter passes all the previous steps, the inverter is ready for use. If the inverter fails any of the steps, refer to the Troubleshooting section.

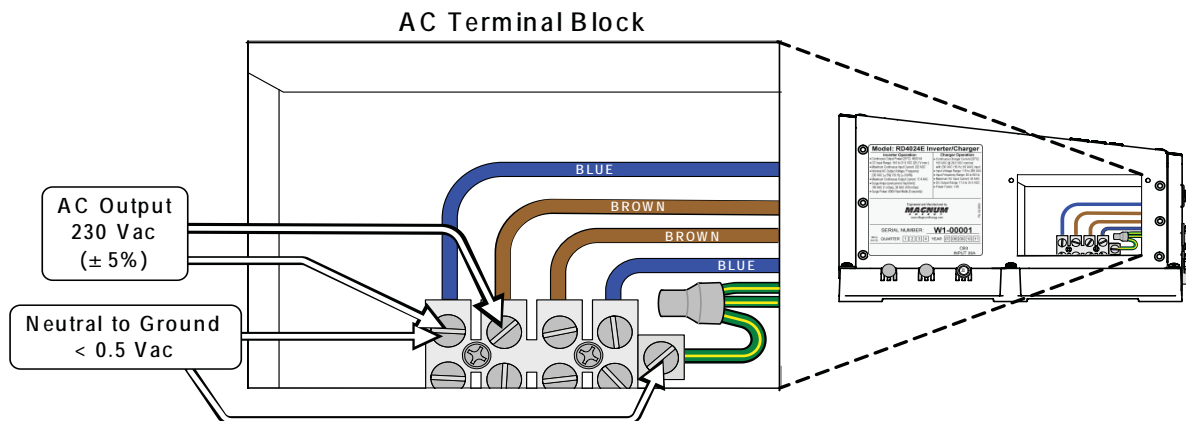

Figure 2-17, AC Voltage Checks

### 3.0 Operation

The RD-E Series inverter has two normal operating routines; Inverter mode, which powers your loads using the batteries, and Standby mode, which transfers the incoming AC power (e.g., utility power or a generator) to power your loads and also uses this incoming power to recharge the batteries. This inverter also includes an extensive protection circuitry to shut down the inverter under certain fault conditions.

#### 3.1 Inverter Mode

When the RD-E Series is first powered up, it defaults to the OFF mode. The momentary Power ON/OFF Switch (see Figure 1-1, Item 1) must be lightly pressed to turn the inverter ON. Subsequently, pressing this switch alternately turns the inverter OFF and ON.

**Inverter OFF** - When the inverter is OFF, no power is used from the batteries to power the AC loads, and the status LED will be OFF. If AC power from an external source (utility power or generator) is connected and qualified on the inverter's AC input, this AC input power will pass through the inverter to power the AC loads. However, if this AC power is lost, the AC loads will no longer be powered because the inverter is OFF.

When the inverter is turned ON, it operates either by "searching" or "inverting", depending on the connected AC loads.

**Searching** - When the inverter is first turned ON, the automatic Search feature is enabled. This feature is provided to conserve battery power when AC power is not required. In this mode, the inverter pulses the AC output looking for an AC load (e.g., electrical appliance). Whenever an AC load (greater than 5 watts) is turned on, the inverter recognizes the need for power and automatically starts inverting. When there is no load (or less than 5 watts) detected, the inverter automatically goes back into Search mode to minimize energy consumption from the battery bank. When the inverter is "searching", the inverter's green LED flashes (fast).



**Info:** The factory default value for the Search feature is 5 watts, it can be turned off or adjusted from 5 to 50 watts using the ME-RC50 remote display.

**Inverting** - When a load greater than 5 watts is connected to the inverter output, the RD-E Series "inverts" the DC power from the battery and supplies 230 VAC power to your sub-panel. The inverter's green LED flashes once every 2 seconds (medium flash) to indicate it is inverting. The amount of time the inverter can be inverting and providing power is directly related to the amount of AC loads that are connected, and the capacity of the battery bank. Refer to Figure 3-1 to see the flow of power from the DC input to the AC output while in the Inverter mode.

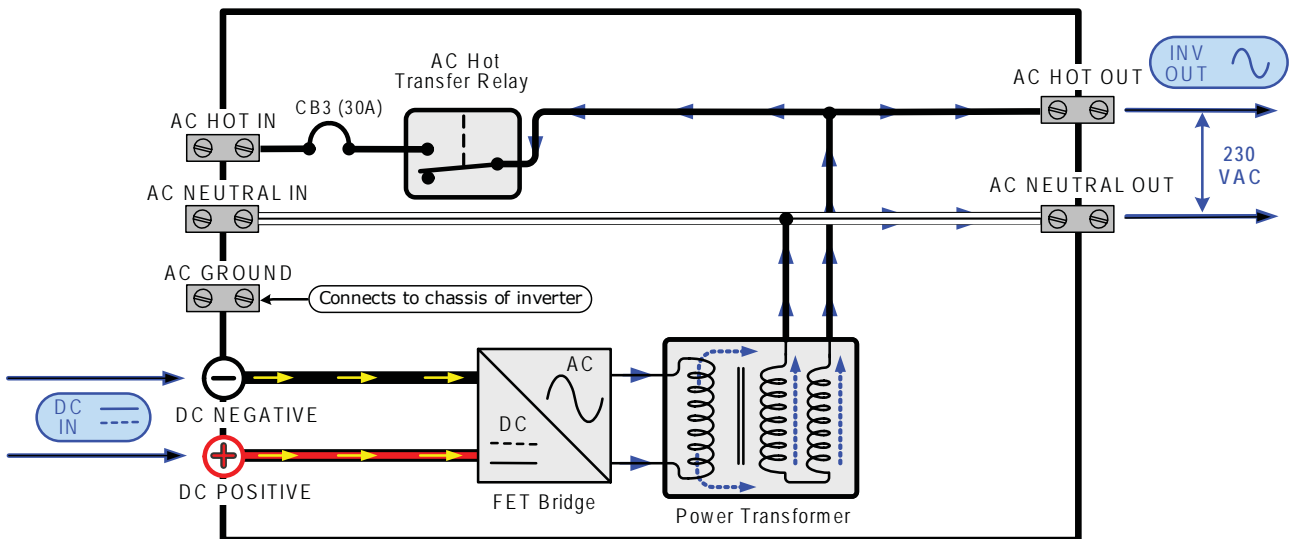

Figure 3-1, Power Flow - Inverter Mode

## Operation

### 3.2 Standby Mode

The RD-E Series features an automatic transfer relay and an internal battery charger when operating in Standby mode. Standby mode begins whenever AC power (utility power or generator) is connected to the inverter's AC input. Once the AC voltage and frequency of the incoming AC power is within the AC input limits, an automatic AC transfer relay is activated. This transfer relay passes the incoming AC power through the inverter to power the AC loads on the inverter's output. This incoming power is also used to activate a powerful internal battery charger to keep the battery bank charged in case of a power failure. Refer to Figure 3-2 to see the flow of power from the AC input to the DC and AC output while in Standby mode.

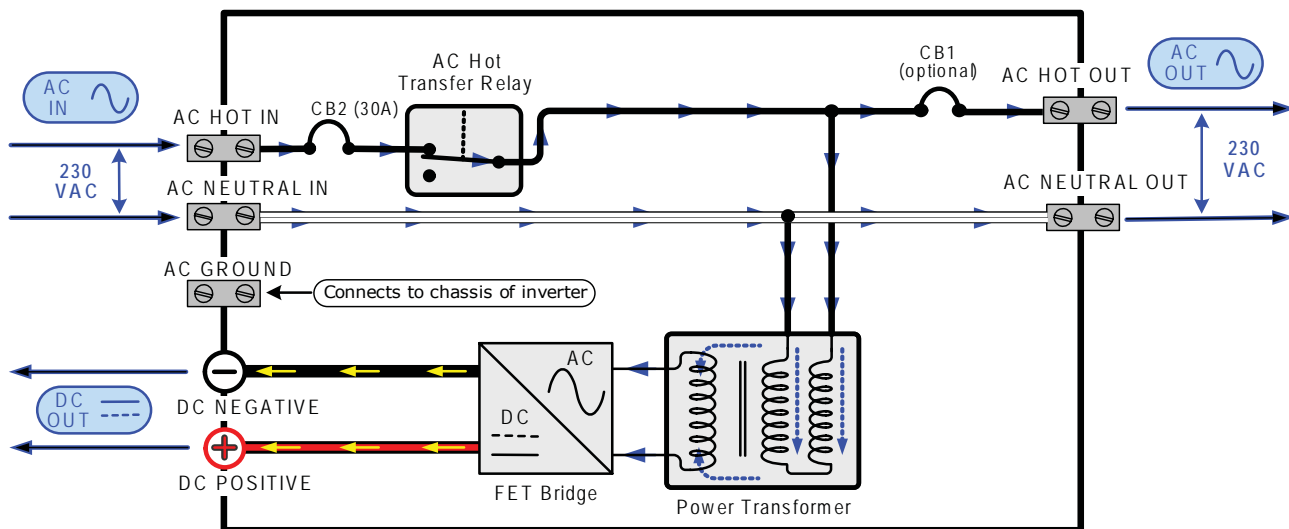

Figure 3-2, Power Flow - Standby Mode

### 3.3 Battery Charging

Magnum Energy's RD-E Series is equipped with an active PFC (Power Factor Corrected) and PI (Proportional-Integral) multi-stage battery charger. The PFC feature is used to control the amount of power used to charge the batteries in order to obtain a power factor as close as possible to 1 (or unity). This causes the battery charger to look like a resistor to the line (forces the charge current wave shape to mirror the voltage wave shape). The PI feature allows the charger voltage and current to change independently. These two features maximize the real power available from either utility power or generator AC power sources, which translates into less power wasted and greater charging capabilities than most chargers available today.

When an AC source is connected to the AC input, the inverter begins monitoring for acceptable AC voltage. Once the inverter has accepted this AC voltage, the AC transfer relay closes and the Charge mode begins. After Charge mode begins, the DC voltage is monitored to determine the charging stage. If the DC voltage is  $\leq 25.6$  VDC, the charger begins Bulk Charging. If the DC voltage is  $>25.6$  VDC, the charger will skip the Bulk and Absorb Charging stages and go directly to Float Charging. The multi-stage charger can use up to five different charging stages to help monitor and keep the batteries properly maintained. The five stages include an automatic 4-stage charging process: Bulk, Absorb, Float, and Full Charge; and a manual Equalization (EQ) Charge stage. The automatic 4-stage charge process provides complete recharging and monitoring of the batteries without damage due to overcharging. The EQ stage (requires the ME-RC50 or ME-ARC50 remote to enable equalization charge) is used to stir up stratified electrolyte and to try to reverse battery plate sulfation that may have occurred.

While charging, the unit may go into Charger Back-off protection, which automatically reduces the charge current to the batteries. This is caused by: 1) the internal temperature is too hot – the charger automatically reduces the charge rate to maintain temperature; or, 2) the AC input voltage falls below 180 VAC – the charger will stop charging to help stabilize the incoming AC voltage.

The Charge mode provides up to four separate charging stages: Bulk Charging, Absorb Charging, Float Charging, and Full Charge (see Figure 3-3).

**Bulk Charging:** This is the initial stage of charging. While bulk charging, the charger supplies the battery with constant current. The charger will remain in bulk charge until the absorption charge voltage (determined by the battery type selection\*) is achieved. The inverter's green LED stays ON (solid) to indicate bulk charging.

**Absorb Charging:** This is the second charging stage and begins after the absorb voltage has been reached. Absorb charging provides the batteries with a constant voltage and reduces the DC charging current in order to maintain the absorb voltage setting. The inverter's green LED flashes once every second (medium flash) to indicate absorption charging for 2 hours (determined by the Battery AmpHrs selection\*), then switches to float charging.

**Float Charging:** The third charging stage occurs at the end of the absorb charging time. While float charging, the charge voltage is reduced to the float charge voltage (determined by the battery type selection\*). In this stage, the batteries are kept fully charged and ready if needed by the inverter. The inverter's green LED flashes once every 8 seconds (slow flash) to indicate float charging. The Float Charging stage reduces battery gassing, minimizes watering requirements (for flooded batteries), and ensures the batteries are maintained at optimum capacity.

**Full Charge (Battery Saver™ mode):** The fourth stage occurs after four hours in the Float Charging stage. The Full Charge stage is designed to keep batteries fully charged over long periods and prevent excessive loss of water in flooded batteries, or drying out of GEL/AGM batteries. In this stage, the charger is turned off and begins monitoring the battery voltage; if the battery voltage drops to 25.4 VDC or less, the charger automatically initiates another four hours in float charge.



**Info:** If the battery voltage falls to the re-bulk voltage (24.2 VDC) or lower, the unit will begin another bulk charge.

\* These settings in the RD-E Series are changeable and leave the factory with default values (see Table 3-2, Inverter/Charger Default Values). These default values are adequate for most installations, however, if you determine that some of the values need to be changed for your particular system, the ME-RC50 or ME-ARC50 remote control may be purchased to adjust these settings.

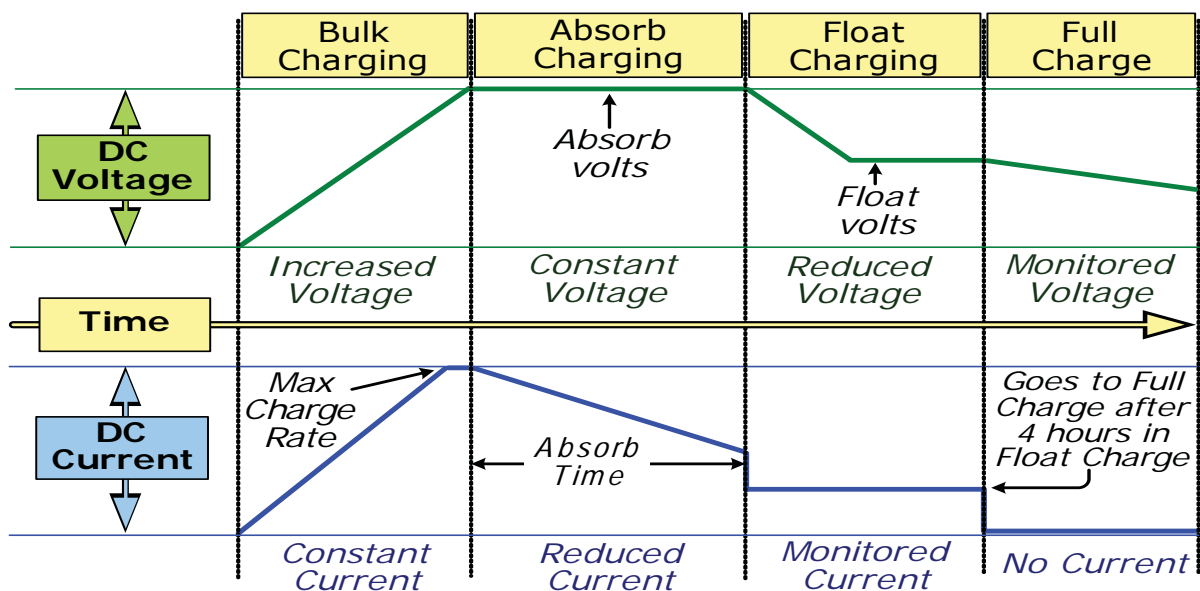

Figure 3-3, Automatic 4-Stage Charging Graph

## Operation

### 3.4 Transfer Time

While in Standby mode, the AC input is continually monitored. Whenever AC power falls below the VAC dropout voltage (160 VAC, default setting), the inverter automatically transfers back to the Inverter mode with minimum interruption to your appliances – as long as the inverter is turned on. The transfer from Standby mode to Inverter mode occurs in approximately 16 milliseconds. While the RD-E Series is not designed as a computer UPS system, this transfer time is usually fast enough to hold them up. However, the VAC dropout setting has an effect on the ability of the loads to transfer without resetting. The lower this setting, the longer the effective transfer will be and therefore, the higher the probability for the output loads to reset. This occurs because the incoming AC voltage is allowed to fall to a level that is so low that when the transfer does occur, the voltage on the inverter's output has already fallen to a level low enough to reset the loads.

The disadvantage of a higher VAC dropout setting is that smaller generators (or large generators with an unstable output) may nuisance transfer. This commonly happens when powering loads that are larger than the generator can handle – causing the generator's output voltage to constantly fall below the inverter's input VAC dropout threshold.



**Info:** When switching from Inverter mode to Standby mode, the inverter waits approximately 15 seconds to ensure the AC source is stable before transferring.

### 3.5 Battery Temperature Sensor Operation

The plug-in Battery Temperature Sensor (BTS) is used to determine the battery temperature around the batteries. This information allows the multi-stage battery charger to automatically adjust the battery charge voltages for optimum charging performance and longer battery life.

When the BTS is installed, if the temperature around the BTS is below 77°F (25°C) the absorb and float charge voltage increases, and if the temperature around the BTS is higher than 77°F (25°C), the absorb and float charge voltage decreases. See Figure 3-4 to determine how much the charge voltage changes (increases or decreases) depending on the temperature reading of the BTS. For example, the nominal absorb charge voltage for a flooded battery at 77°F (25°C) on a 24-volt model is 29.2 VDC. If the battery temperature is 95°F (35°C), the absorb charge voltage would decrease to 28.6 VDC (29.2 VDC - 0.6 change).

If the temperature sensor is NOT installed, the charge voltages will not be compensated and the battery will maintain the charge it had at a temperature of 77°F (25°C). The life of the batteries may be reduced if they are subjected to large temperature changes when the BTS is not installed.



**Info:** When the BTS is connected, the battery charger uses a value of 5mV/°C/Cell from 0-50°C to change the charge voltage based on temperature.

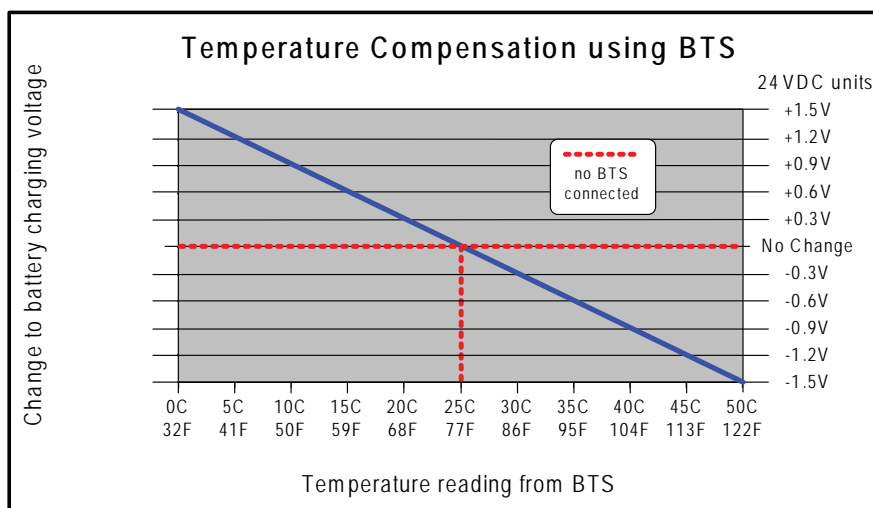

Figure 3-4, BTS Temperature to Charge Voltage Change

### 3.6 Protection Circuitry Operation

The inverter is protected against fault conditions, and in normal usage it will be rare to see any. However, if a condition occurs that is outside the inverter's normal operating parameters, it will shut down and attempt to protect itself, the battery bank, and your AC loads. If there is a condition that causes the inverter to shut down, it may be one of the following conditions [also refer to the Troubleshooting section (Section 4.2) to help diagnose and clear the fault condition]:

- **Low Battery** - The inverter will shut off whenever the battery voltage falls to the Low Battery Cut Out (**LBCO**) level to protect the batteries from being over-discharged. After the inverter has reached the LBCO level and turned off, the inverter will automatically restart after one of the following conditions:

AC Power is applied and the inverter begins operating as a battery charger, or battery voltage rises to the Low Battery Cut In (**LBCI**) level.

The inverter's status LED turns off when a low battery fault condition occurs. Refer to Table 3-1 to determine the LBCO and LBCI levels for your particular inverter model.

- **High Battery** - In the event the battery voltage approaches the High Battery Cut Out (**HBCO**) level, the inverter will automatically shut down to prevent the inverter from supplying unregulated AC output voltage. The inverter's status LED turns off when a high battery fault condition occurs. The inverter will automatically restart when the battery falls to the High Battery Cut In (**HBCI**) level. Refer to Table 3-1 to determine the HBCO and HBCI levels for your inverter model.



**Info:** High battery voltage may be caused by excessive or unregulated voltage from solar panels or other external charging sources.

- **Overload** - During inverter and standby operation, the inverter monitors current levels. In the event of a short-circuit or an overload condition for more than a few seconds, the inverter will shut down. To start operating after this fault, the inverter would need to be restarted (turned back on) after the inverter's AC loads are reduced/removed.
- **Over-temperature** - If internal power components begin to exceed their safe operating temperature level, the inverter will shut down to protect itself from damage. The inverter's status LED turns OFF to indicate the over-temperature fault condition. The inverter will automatically restart after the units cool down.
- **Internal Fault** - The inverter continually monitors several internal components and the processor communications. If a condition occurs that does not allow proper internal operation, the inverter will shut down to protect itself and the connected loads. The inverter will need to be reset to start operating again (refer to Section 4.3 for information on resetting the inverter).

**Table 3-1, Inverter Battery Turn On/Off Levels**

Inverter battery turn ON/OFF Levels	Inverter Model	
	RD2624E	RD4024E
HBCO	>31.6 VDC	>31.6 VDC
HBCI	31.0 VDC	31.0 VDC
LBCI	≥25.0 VDC	≥25.0 VDC
LBCO* (1 minute delay)	20.0 VDC (18.0 - 24.4 VDC)	20.0 VDC (18.0 - 24.4 VDC)
LBCO (immediate)	17.0 VDC	17.0 VDC

*\*adjustable with remote control*



### 3.7 Inverter Startup

**ON/OFF Switch** - The inverter can be turned on and off by lightly pressing and releasing the Power ON/OFF switch on the front of the inverter (see Figure 3-5). When the inverter is first connected to the batteries, or when its automatic protection circuit has turned the inverter off, the ON/OFF switch will need to be pressed to start the unit (or reset per Section 4.3). Once the inverter has been turned on, pressing the Power ON/OFF switch alternately turns the inverter on and off.



**WARNING:** The Power ON/OFF control switch does not turn on or off the charger feature. If AC power (utility power or generator) is connected and qualified on the AC input, this AC power will also be available on the AC output and is not controlled by the Power ON/OFF switch.

**Status LED Indicator** - The status indicator is a green LED (Light Emitting Diode) that provides information on the operational mode of the inverter. Watch this indicator (see Figure 3-5) for at least 10 seconds to determine the inverter's operational condition from the information below:

- **Off** - Indicates the inverter is off; there is no AC power (inverter, utility power, or generator) at the inverter's output terminals. If the LED stays off after pressing the ON/OFF switch, there is a "fault condition" such as low battery, high battery, overload, over-temperature, or an internal fault. Refer to the Troubleshooting section to help diagnose/clear the fault condition.
- **Slow flash** (blinks on once every 8 seconds) - Indicates float charging; the inverter is in Standby mode (the external AC power that is connected to the inverter's input is passing through the inverter and is powering the AC loads connected to the inverter's output).
- **Medium flash** (blinks on once every second):

When AC power is not connected to inverter input - Indicates the inverter is on and using energy from the battery. The inverter is either: 1) Inverting - providing full power to the loads connected to the inverter; or, 2) Searching - conserving power and waiting for a load to be turned on that meets or exceeds the search watts parameter (5 watts is the inverter default setting).

When AC power is connected to inverter input - Indicates absorb charging; the inverter is in Standby mode (the external AC power that is connected to the inverter's input is passing thru the inverter and is powering the AC loads connected to the inverter's output).

- **On (solid)** - Indicates bulk charging; the inverter is in Standby mode (the external AC power that is connected to the inverter's input is passing thru the inverter and is powering the AC loads connected to the inverter's output).

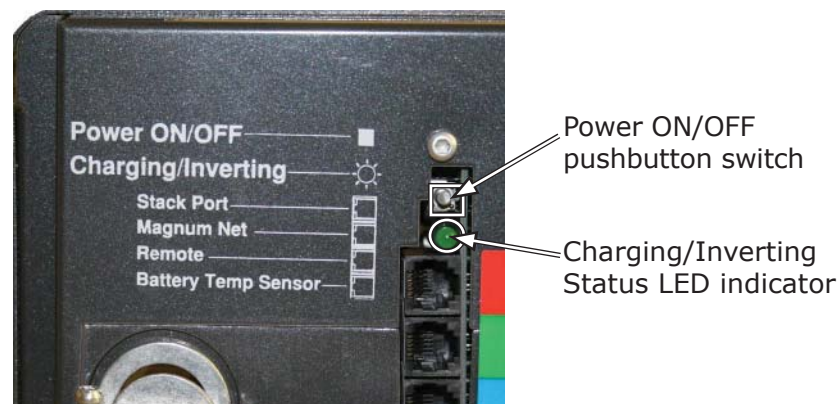

*Figure 3-5, Power Switch and Status Indicator*

### 3.8 Factory Default Values

Your RD-E Series inverter/charger uses default values for the adjustable settings (see Table 3-2) that are adequate for most installations. If some of your operating parameters need to be changed from the default values, the optional ME-RC50 or ME-ARC50 remote control can be used to make those changes. To help you determine if you need a remote display, information on the inverter/charger settings that can be changed is provided below. The settings, once programmed, are saved in the remote's non-volatile memory and are preserved until changed – even if DC power to the inverter is lost (as long as the ME-RC50/ME-ARC50 remote is connected). For information on the full range of settings for each function, refer to the ME-RC50 or ME-ARC50 Owner's Manual at [www.magnumenergy.com](http://www.magnumenergy.com).

- **Shore:** This setting ensures the inverter AC loads receive the maximum current available from the utility power or generator. When the total current used to power the AC loads and to charge the batteries begins to approach the "Shore" setting, the current that was used for charging the batteries will automatically be reduced.
- **01 Search Watts:** This setting allows you to turn off the power-saving Search mode circuitry or adjust the power level at which the inverter will "wake up" and start inverting.
- **02 LowBattCutOut:** This setting determines when the inverter will turn off based on low battery voltage. The inverter turns off automatically after the battery voltage has been below this setting for more than one minute. This protects the batteries from over-discharge and the AC loads from unregulated power (brown-outs).
- **03 Batt AmpHrs:** This setting allows the user to input the battery bank size in amp hours, which tells the charger how long to charge the batteries in the Absorb Charge stage.
- **04 Battery Type:** Sets the type of batteries being used in the system; this information tells the charger what voltage level to use to charge the batteries.
- **05 Charge Rate:** This setting can be used to turn off the charger, limit the amount of current that the charger can use (leaving more current available to power loads); or, to ensure small battery banks are not overheated because of a too high charge rate.
- **06 VAC Dropout:** Sets the minimum AC voltage that must be present on the AC input before the unit transfers from Standby mode to Inverter mode. This protects the AC loads from utility power outages and brown-outs.

Using the ME-RC50 or ME-ARC50 remote also provides the following features:

- allows you to enable an equalize charge for certain battery types
- displays inverter/charger's operating status
- provides fault information for troubleshooting

**Table 3-2, Inverter/Charger Default Values**

Adjustable Settings	Default Values
Shore	30 amps
01 Search Watts	5 watts
02 LowBattCutOut	20 VDC
03 Batt AmpHrs	600 Amp Hours (Absorb Time = 120 minutes)
04 Battery Type	Flooded - Liquid Lead Acid
05 Charge Rate	100%
06 VAC Dropout	160 VAC

### 4.0 Maintenance and Troubleshooting

The following information is provided to help you keep your RD-E Series inverter/charger in optimum operational condition.

#### 4.1 Recommended Inverter and Battery Care

The RD-E Series inverter/charger is designed to provide you with years of trouble-free service. Even though there are no user-serviceable parts, it is recommended that every 6 months you perform the following maintenance steps to ensure optimum performance and extend the life of your batteries.



**WARNING:** Prior to performing the following checks, switch OFF both the AC and DC circuits.

- Visually inspect the batteries for cracks, leaks, or swelling – replace if necessary.
- Use baking soda to clean and remove any electrolyte spills or buildups.
- Check and tighten all battery holddown clamps (if applicable).
- Clean and tighten all battery terminals and connecting cables [10 to 12 ft lbf (13.6 to 16.3 N-m)].
- Check and fill battery water levels (Liquid Lead Acid batteries only).
- Check individual battery voltages (load test those that have a voltage difference of more than 0.3 VDC from each other) – replace if necessary.
- Check all cable runs for signs of chafing – replace if necessary.
- Check the inverter's cooling vents – clean as necessary.
- Check and tighten the inverter's internal AC terminal block connections [16 in lbf (1.8 N-m)].

## 4.2 Troubleshooting

The RD-E Series inverter/charger is a fairly simple device to troubleshoot. There are only two active circuits (AC and DC) as well as a charging circuit. The following chart is designed to help you quickly pinpoint the most common inverter failures.

<b>Table 4-1, Basic Troubleshooting</b>		
<b>Symptom</b>	<b>Possible Cause</b>	<b>Recommended Solution</b>
No output power/ Inverter LED is OFF.	Inverter is switched OFF.	Switch the inverter ON.
	Battery voltage is too low. The battery voltage level has dropped below the Low Battery Cut Out (LBCO) set-point for more than one minute.	Check fuses/circuit breakers and cable connections. Check battery voltage at the inverter's terminals. Your batteries may need to be charged, and this fault condition will automatically clear when the battery voltage exceeds the LBCI voltage.
	The battery voltage is too high. The inverter automatically resets and resumes operation when the battery voltage drops to the HBCI voltage or lower.	This condition usually only occurs when an additional charging source (alternator, solar panels, or other external charging sources) is used to charge the battery bank. Reduce or turn off any other charger to the inverter batteries to allow the voltage level to drop.
	Over-temperature condition: The internal temperature of the inverter has risen above acceptable limits; caused by loads too great for the inverter to operate continuously, or by lack of ventilation to the inverter. When the unit has cooled, it will automatically reset and resume operation.	Reduce the number of electrical loads that you are operating. This will avoid a repeat over-temp shutdown if the cause was too many loads for the ambient conditions.
		Check ventilation around the inverter, ensure cool air is available to pass through the inverter (refer to the ventilation requirements in Section 2.1.3).
	AC overload condition: The inverter has turned off because the connected loads are larger than the inverter's output capacity, or the output wires are shorted.	Reduce the AC loads connected to the inverter, or remove all AC output wiring and restart the inverter.
Internal fault: This fault occurs when an internal fault is detected.	To clear this fault, an inverter reset is required. Remove DC power to the inverter, or press and hold down the power switch on the inverter for 15 seconds (until the green status LED comes on). If this fault does not clear, the unit will need to be serviced.	
No output power/ Green LED is flashing.	Unit is in Search mode, which means the load is too small for Search mode circuit detection.	Turn on a load greater than 5 watts to bring the inverter to full output power, or turn off Search with remote.
Low output or surge power/ Green LED is flashing.	Loose or corroded battery cables.	Clean and tighten all cables.
	Low batteries.	Recharge or replace batteries.
	Loose AC output connections.	Tighten AC output connections.
	Battery cables are the wrong length or gauge.	Verify recommended cable lengths and gauges from the manual. Replace cables as necessary.
Low charging rate when connected to AC power.	Charge rate set too low.	Adjust charge rate or SHORE settings on remote.
	Low AC voltage (< 180 VAC).	Check AC input wiring.
Low charging rate when using a generator.	Generator output is too low to power both the load and the charger.	Reduce the load, increase the generator's RPMs.
		Check the SHORE (or input amps) settings (if remote connected).
Charger doesn't charge.	Loose or corroded battery cables.	Clean and tighten battery cables.
	Defective batteries.	Replace batteries.
	Wrong charger settings.	Adjust the charger settings, ensure the unit is not in Charger Standby.
	Wrong AC input voltage.	Verify proper AC input voltage and frequency.

## Maintenance and Troubleshooting

### 4.3 Resetting the Inverter

Under some fault conditions (e.g., an internal fault), the inverter will need to be reset.

#### To reset the inverter:

Press and hold the Power ON/OFF pushbutton (see Figure 4-1) for approximately fifteen (15) seconds until the Charging/Inverting Status LED comes on and flashes rapidly; once the rapid flashing has begun, release the Power ON/OFF pushbutton. The Status LED will go off after the pushbutton is released.

After the inverter reset is completed, press the ON/OFF pushbutton to turn the inverter ON.



**Info:** The Power ON/OFF pushbutton is a small *momentary* type switch which operates by lightly pressing and releasing.

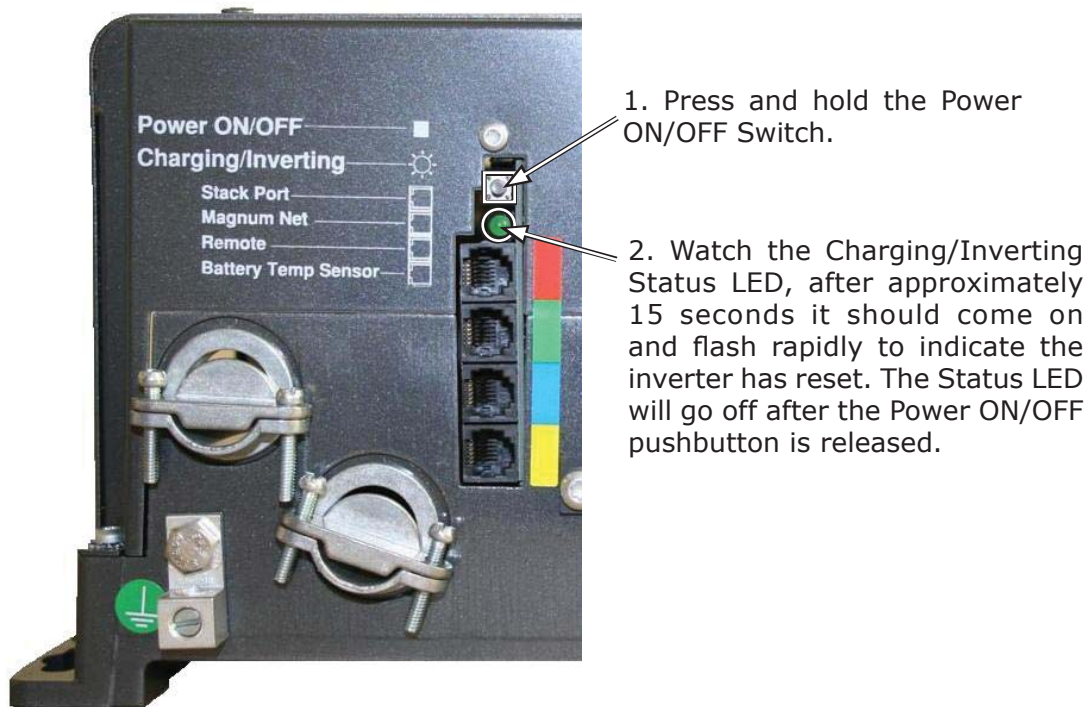

*Figure 4-1, Performing an Inverter Reset*

## Appendix A - Specifications and Optional Equipment

## A-1 Inverter/Charger Specifications

Models	RD2624E	RD4024E
<b>Inverter Specifications</b>		
Input battery voltage range	18 to 31 VDC	18 to 31 VDC
Absolute maximum DC input	35 VDC	35 VDC
AC output voltage accuracy	230 VAC $\pm$ 5%	
Output frequency and accuracy	50 Hz $\pm$ 0.1 Hz	
Continuous power output (at 25° C)	2600 VA	4000 VA
1 msec surge current (amps AC)	85	100
100 msec surge current (amps AC)	22	40
5 sec surge power (real watts)	4700	7500
30 sec surge power (real watts)	4100	6750
5 min surge power (real watts)	3350	6000
30 min surge power (real watts)	2700	5500
Maximum continuous input current	173 ADC	267 ADC
Inverter efficiency (peak)	93%	93%
HBCO/HBCI (High Battery Cut Out/In)	$\geq$ 31.6 VDC	$\geq$ 31.6 VDC
LBCO/LBCI (Low Battery Cut Out/In)	18 VDC (adj)/25 VDC	18 VDC (adj)/25 VDC
Series stacking 120/240 VAC	NA	
Transfer time	30ms	20ms
Search mode (typical)	<7 watts	<8 Watts
No load (230 VAC output, typical)	22 watts	32 watts
Waveform	Modified Sine Wave	
<b>Charger Specifications</b>		
Continuous Output at 25°C	75 ADC	105 ADC
Input Current - Rated Output (AC amps)	11.5	16
Charger Efficiency	87%	85%
AC Input Frequency Range	40-60 Hz	
AC Input Voltage Range	115-268 VAC	
Power Factor	>0.95	
<b>General Features and Capabilities</b>		
Transfer relay capability	30 AAC	
Five-stage charging capability	Bulk, Absorb, Float, Equalize (requires remote), and Battery Saver™	
Battery temperature compensation	Yes, 15 ft. Battery Temperature Sensor standard	
Internal cooling	0 to 120 cfm variable speed	
Overcurrent protection	Yes, with two overlapping circuits	
Over-temperature protection	Yes, on transformer, MOSFETS, and battery	
Corrosion protection	Yes, conformal coated PCBs, powder coated chassis and top, stainless steel fasteners	
Safety listings	None	
Warranty	Two years	
Dual branch-rated output breakers	NA	
<b>Environmental Specifications</b>		
Operating temperature	-20° C to + 60° C (-4° F to 140° F)	
Non-operating temperature	-40° C to + 70° C (-40° F to 158° F)	
Operating humidity	0 to 95% RH non-condensing	
<b>Physical Specifications</b>		
Unit dimensions (h x w x d)	13.75" x 12.65" x 8.0" (34.9 cm x 32.1 cm x 20.3 cm)	
Shipping dimensions (h x w x d)	18.5" x 17.5" x 12.5" (47 cm x 44.5 cm x 31.8 cm)	
Mounting	Shelf (top or bottom up) or wall	
Unit weight	42 lb (19.1 kg)	55 lb (25 kg)
Shipping weight	47 lb (21.3 kg)	60 lb (27.2 kg)
Max operating altitude	15,000 ft (4570 m)	
<i>Specifications @ 25° C - Subject to change without notice.</i>		

## Appendix A - Specifications

### A-2 Optional Equipment and Accessories

The following Magnum Energy components are available for use with the RD-E Series inverter/charger. Some of these items are required depending upon the intended use of the inverter.

#### MMP Series Enclosures

The MMP175-30D, MMP175-60S, MMP250-30D, and MMP250-60S enclosures are for single inverter applications. The MMP Series enclosures have been specifically designed to combine all of the major components required for a renewable energy system — inverter/battery disconnect, AC overcurrent protection, grounding connections, and a full system inverter bypass switch as a convenient way to isolate the inverter for battery maintenance — into a single, easy to install pre-wired enclosure.

#### Smart Battery Combiner

The Smart Battery Combiner (ME-SBC™) is designed to monitor and charge a second battery using a portion of the current that is charging the main battery. The ME-SBC eliminates a significant voltage drop, and provides automatic turn-on and turn-off based on adjustable voltage set-points. This allows different batteries to be charged from a single charging source, and prevents overcharging/undercharging.

#### Remote Switch Adapters

The ME-RSA™ and ME-RSA-M™ pigtail adapters allow the inverter to be remotely switched on and off – with or without the ME-RC50 remote display.

#### Basic Remote Control

The ME-RC50 Remote Control Panel is simple to use; an LCD screen and “at a glance” LEDs display complete inverter/charger status. Soft keys provide simple access to menus and a rotary encoder knob allows you to scroll through and select a wide range of settings such as Inverter ON/OFF, Charger ON/OFF, Utility Power Breaker Setting, AGS Control, Meter Button, Setup and Tech menus.

#### Advanced Remote Control

The ME-ARC50 Remote Control Panel uses an LCD screen and “at a glance” LEDs to provide operating information and allow advanced features to be configured (requires Magnum inverters with advanced configurable features). This LCD remote control also provides advanced monitoring/troubleshooting and includes a FAVS button to access your favorite features quickly.

#### Auto Generator Start Controller

The ME-AGS-N Automatic Generator Start controller (Network version) is designed to automatically start your generator based on low battery condition or high temperature. The AGS controller includes an input voltage jumper (for 12, 24, and 48 volt battery banks) and a 4-position DIP (Dual In-line Package) switch which provides the ability to change the relay timing configurations to allow compatibility with a wider range of generators. Adjustable settings when using the ME-ARC50 include starting the generator based on: Battery Voltage, Time Of Day, Battery 'State of Charge' or High Temperature.

#### Battery Monitor Kit

The ME-BMK Battery Monitor Kit is a single battery bank amp-hour meter that monitors the condition of the battery and provides information to let you know how much energy you have available and let you plan your electrical usage to ensure the battery is not being over-discharged. The ME-BMK-NS version does not include a DC shunt – order the ME-BMK to receive a 500A/50mv DC shunt.

#### Fuse Block/Fuses

The Magnum Fuse/Fuse-blocks are used to protect the battery bank, inverter, and cables from damage caused by DC short circuits and overloads. They include a slow-blow fuse with mounting block and protective cover. The 125 and 200 amp models use an ANL type fuse and the 300 and 400 amp models use a Class-T fuse.

**A-3 Wiring Color Codes for Europe and the U.S./Canada**

The following tables contrast AC and DC wiring color codes for Europe and the United States/Canada. In the U.S., the National Electrical Code (NEC) is the mandating authority; in Canada, it's the Canadian Electrical Code (CEC). Most of Europe abides by the International Electrotechnical Commission's (IEC) wiring color codes. The tables also list the labels that Magnum Energy applies to identify AC/DC wiring usage in its inverters.

***Table A-1, AC Wiring Color Codes***

<b>Use</b>	<b>Magnum Label</b>	<b>Europe</b>	<b>U.S./Canada</b>
Protective earth	AC GROUND	Green w/ yellow stripe	Bare, green
Neutral (out/in)	NEUTRAL OUT/NEUTRAL IN	Blue	White (marked white)
Line, single phase (out/in)	HOT OUT/HOT IN	Brown	Black

***Table A-2, DC Wiring Color Codes\****

<b>Use</b>	<b>Magnum Label</b>	<b>Europe</b>	<b>U.S./Canada</b>
Positive circuit	Positive (+) terminal (w/ red cover)	Brown	Red
Negative circuit	Negative (-) terminal (w/ black cover)	Blue	White



# Appendix B - Battery Information

## B-1 Battery Location

Periodic maintenance (e.g., checking connections, cleaning, watering) on batteries is required. Locate the batteries in an accessible location to perform this maintenance.

Batteries must be mounted in a clean, dry, ventilated environment where they are protected from high and low temperatures. The battery bank should be located as close to the inverter as possible without limiting access to the inverter's disconnects. Longer battery cable runs tend to lose efficiency and reduce the overall performance of an inverter.

To ensure optimum performance, a ventilated battery enclosure is recommended. Two feet (61 cm) of clearance above the batteries is recommended for access to the battery terminals and removable caps (lead acid battery types).



**WARNING:** Be very careful when working around batteries, they can produce extremely high currents if they are short-circuited. Read the important safety instructions at the beginning of this manual and the precautions from the battery supplier before installing the inverter and batteries.



**CAUTION:** Do not mount the batteries beneath the inverter (or in the same compartment). Batteries emit corrosive fumes which could damage the inverter's electronics. Never locate dedicated batteries near a home fuel tank containing propane.

## B-2 Battery Types

Batteries are available in different sizes, amp-hour ratings, voltage, and chemistries. They are also available for starting applications (such as an automobile starting battery) and deep discharge applications. Only the **deep cycle** types are recommended for inverter applications; using a starting battery in an inverter (deep cycle) application will greatly shorten their useful life. Choose the batteries best suited for the inverter installation and cost. Use only the same battery type for all batteries in the bank. For best performance, all batteries should be from the same lot and date. This information is usually printed on a label located on the battery.

## B-3 Battery Temperature

Battery performance of lead-acid type batteries is greatly affected by extreme temperatures. When a lead-acid type battery is cold, its effective amp-hour capacity is reduced. When determining the battery requirements needed for the inverter system, realize that the battery capacity will be reduced if they will be installed in a climate where extremely cold temperatures are expected. In this type of environment, the batteries should be located in a heated area. At the minimum, the batteries should be installed in an insulated enclosure; which will keep the batteries warmer as they are being charged.

The battery bank should also be protected from high temperatures, which will shorten battery life. In high heat situations the battery room/enclosure should be ventilated to bring in cooler air and exhaust the hotter air. The performance of the battery bank/inverter system will substantially increase by monitoring and preventing extreme temperatures around the batteries.

## B-4 Battery Bank Sizing

The size of the battery bank determines how long the inverter will power the AC loads without recharging. The larger the battery bank, the longer the run time. Size your battery bank to the systems AC load requirements and length of time required to run from the batteries. In general, the battery bank should not be discharged more than 50%. Additional DC charging devices such as solar, wind, hydro, etc., can provide longer run times by recharging the batteries in the absence of AC utility power or generator power.



**Info:** For the RD-E Series inverter/charger to perform optimally, a minimum battery bank of 200 AH is recommended for moderate loads (<1000W) and greater than 400 AH for heavy loads (≥1000W).

**B-5 Battery Bank Sizing Worksheet**

Complete the steps below to determine the battery bank size required to power your AC loads:

**1. Determine the daily power needed for each load**

- a) List all AC loads required to run; and
- b) List the Watt-Hours for each load (see Table B-1 for common loads/wattage); and
- c) multiply by how many hours per day (or a fraction of an hour) each load will be used; and
- d) multiply by how many days per week you will use the listed loads; and
- e) divide by seven = **Average Daily Watt-Hours Per Load.**

Average Daily Watt-Hours Per Load				
AC load	Watt-Hours	(x) hours per day	(x) days per week	(÷7) = total power

**2. Determine the total power needed each day for all the loads.**

- Add the *Average Daily Watt-Hours Per Load* together = **Total Daily Watt-Hours.**

Total Daily Watt-Hours

**3. Determine the battery Amp-Hour capacity needed to run all the loads before recharging.**

- Divide the *Total Daily Watt-Hours* by the nominal battery voltage of the inverter (i.e., 24 volts); and
- Multiply this by how many days the loads will need to run without having power to recharge the batteries (typically 3 to 5 days of storage) = **Storage Amp-Hours.**

(inverter battery voltage)

÷ \_\_\_\_\_ =

(days of storage)

x \_\_\_\_\_ =

**4. Determine how deeply you want to discharge your batteries.**

- Divide the *Storage Amp-Hours* by 0.2 or 0.5 to get the **Total Amp-Hours:**
  - a) 0.2 = Discharges the batteries by 20% (80% remaining), this is considered the optimal level for long battery life; or
  - b) 0.5 = Discharges the batteries by 50% (50% remaining), this is considered a realistic trade-off between battery cost and battery life.

Total Amp-Hours

**Additional compensation:**

Low battery temperature: If the batteries are installed in a location that will be exposed to low temperatures, the available output will be less. In these instances, you will need to determine the lowest temperature the battery bank will experience and multiply the *Total Amp-Hours* by the Multiplier below.

Temperature	80F/27C	70F/21C	60F/15C	50F/10C	40F/4C	30F/-1C	20F/-7C
Multiplier	1.00	1.04	1.11	1.19	1.30	1.40	1.59

Inverter efficiency: When the inverter is used in a back-up power application the inverter efficiency will not be a large concern; however if the inverter is the primary AC source for the calculated load, the *Total Amp-Hours* should be multiplied by 1.2 to factor in an average 80% inverter efficiency.

## Appendix B - Battery Information

### B-6 Battery Wiring Configurations

The battery bank must be wired to match the inverter's DC input voltage. In addition, the batteries can be wired to provide additional run time. The various wiring configurations include:

#### B-6.1 Series Wiring

Wiring batteries in series increases the battery bank's output voltage. A series connection combines each battery in a string until the total voltage matches the inverter's DC requirement. Even though there are multiple batteries, the capacity remains the same. In Figure B-1 below, two 6 VDC/200 AH batteries are combined into a single string resulting in a 12 VDC, 200 AHr bank.

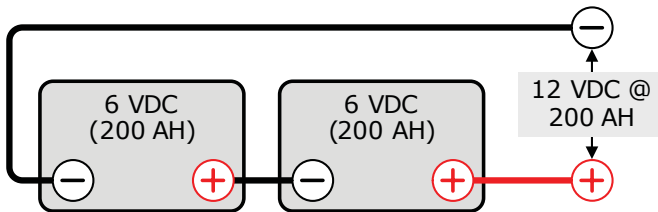

**Series Battery Wiring**  
combines battery voltage:

$$\begin{array}{r} 200 \text{ AH @ } 6 \text{ VDC} \\ + \\ 200 \text{ AH @ } 6 \text{ VDC} \\ = \\ 200 \text{ AH @ } 12 \text{ VDC} \end{array}$$

Figure B-1, Series Battery Wiring

#### B-6.2 Parallel Wiring

Wiring batteries in parallel increases the battery bank's amp-hour capacity, which allows the AC loads to operate for a longer time. A parallel connection combines the number of batteries in the string to increase overall battery capacity; however, the voltage remains the same. In Figure B-2 below, two 12 VDC/100 AH batteries are combined into a single 12 VDC, 200 AH battery bank.

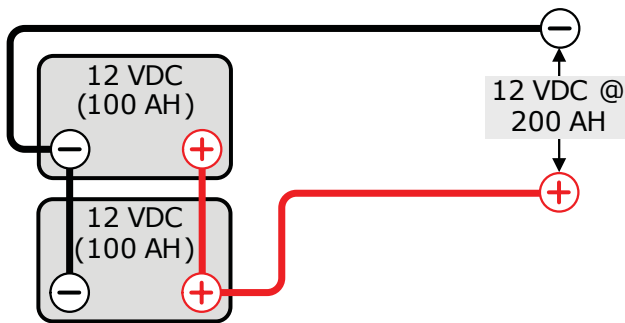

**Parallel Battery Wiring**  
combines battery capacity:

$$\begin{array}{r} 100 \text{ AH @ } 12 \text{ VDC} \\ + \\ 100 \text{ AH @ } 12 \text{ VDC} \\ = \\ 200 \text{ AH @ } 12 \text{ VDC} \end{array}$$

Figure B-2, Parallel Battery Wiring

#### B-6.3 Series-Parallel Wiring

A series/parallel configuration increases both voltage (to match the inverter's DC requirements) and Amp-Hour capacity (to increase run-time for operating the loads) using smaller, lower-voltage batteries. In Figure B-3 below, four 6 VDC/200 AH batteries are combined into two strings resulting in a 12 VDC, 400 AH battery bank.

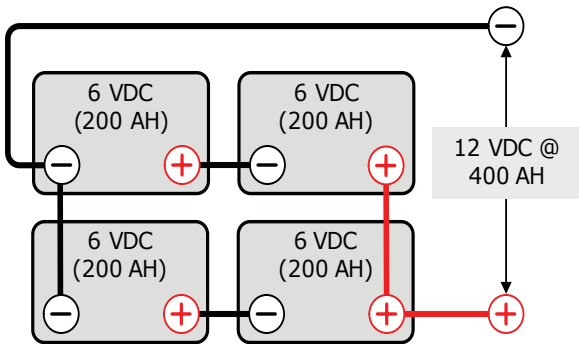

**Series/Parallel Battery Wiring**  
combines battery voltage and capacity:

$$\begin{array}{r} 200 \text{ AH @ } 6 \text{ VDC} \\ + \\ 200 \text{ AH @ } 6 \text{ VDC} \\ \hline 200 \text{ AH @ } 12 \text{ VDC} \\ + \\ 200 \text{ AH @ } 6 \text{ VDC} \\ + \\ 200 \text{ AH @ } 6 \text{ VDC} \\ \hline 200 \text{ AH @ } 12 \text{ VDC} \\ \hline 400 \text{ AH @ } 12 \text{ VDC} \end{array}$$

add voltage in series      add capacity in parallel      add voltage and capacity together

Figure B-3, Series-Parallel Battery Wiring

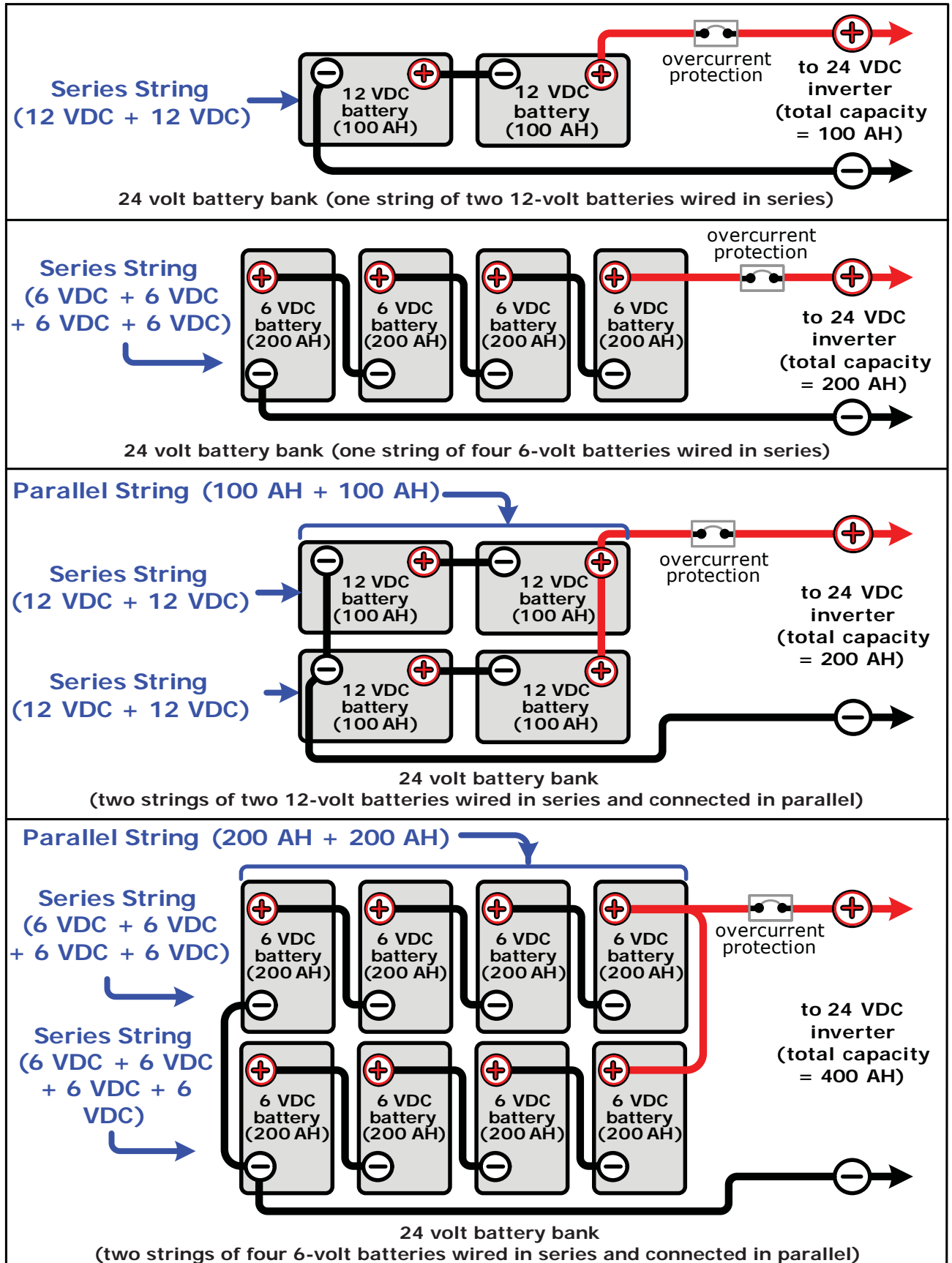

Figure B-4, Battery Bank Wiring Examples (24-volt)

### Limited Warranty

Magnum Energy, Inc., warrants the RD-E Series inverter/charger to be free from defects in material and workmanship that result in product failure during normal usage, according to the following terms and conditions:

1. The limited warranty for the product extends for 24 months beginning from the product's original date of purchase.
2. The limited warranty extends to the original purchaser of the product and is not assignable or transferable to any subsequent purchaser.
3. During the limited warranty period, Magnum Energy will repair, or replace at Magnum Energy's option, any defective parts, or any parts that will not properly operate for their intended use with factory new or remanufactured replacement items if such repair or replacement is needed because of product malfunction or failure during normal usage. The limited warranty does not cover defects in appearance, cosmetic, decorative or structural parts or any non-operative parts. Magnum Energy's limit of liability under the limited warranty shall be the actual cash value of the product at the time the original purchaser returns the product for repair, determined by the price paid by the original purchaser. Magnum Energy shall not be liable for any other losses or damages.
4. Upon request from Magnum Energy, the original purchaser must prove the product's original date of purchase by a dated bill of sale, itemized receipt.
5. The original purchaser shall return the product prepaid to Magnum Energy in Everett, WA. After the completion of service under this limited warranty, Magnum Energy will return the product prepaid to the original purchaser via a Magnum-selected non-expedited surface freight within the contiguous United States and Canada; this excludes Alaska and Hawaii.
6. This limited warranty is voided if:
  - the product has been modified without authorization
  - the serial number has been altered or removed
  - the product has been damaged from abuse, neglect, accident, high voltage or corrosion
  - the product was not installed and operated according to the owner's manual

### How to Receive Repair Service

If your product requires warranty service or repair, contact either:

1. An Authorized Service Center, which are listed on the Magnum Energy website at [www.magnumenergy.com/servicecenters.htm](http://www.magnumenergy.com/servicecenters.htm); or
2. Magnum Energy, Inc. at:

Telephone: 425-353-8833

Fax: 425-353-8390

Email: [warranty@magnumenergy.com](mailto:warranty@magnumenergy.com)

If returning the product directly to Magnum Energy for repair, you must:

- return the unit in the original, or equivalent, shipping container
- receive a Return Materials Authorization (RMA) number from the factory prior to the return of the product to Magnum Energy for repair
- place RMA numbers clearly on the shipping container or on the packing slip

When sending your Product for service, please ensure it is properly packaged. Damage due to inadequate packaging is not covered under warranty. We recommend sending the Product by traceable or insured service.

**BEFORE RETURNING ANY UNIT TO MAGNUM ENERGY INC.,  
A RETURN MATERIAL AUTHORIZATION (RMA) NUMBER IS REQUIRED**



Magnum Energy, Inc.  
2211 West Casino Rd.  
Everett, WA 98204  
Phone: 425-353-8833  
Fax: 425-353-8390  
Web: [www.magnumenergy.com](http://www.magnumenergy.com)